

fischertechnik Computing	p. 16
Before you get started	p. 16
Assembly	p. 16
Important Components	p. 16
Interface and Software	p. 18
Your first programming steps	p. 18
Programming Tasks Part 1	p. 19
Handdryer	p. 19
Traffic Light	p. 20
Sliding Door	p. 21
Programing Tasks Part 2	p. 23
Temperature Control	p. 23
Stamping Press	p. 24
Car Park Barrier	p. 25
Welding Robot	p. 26
What else can you do?	p. 27

Contents



fischertechnik Computing

■ Welcome to our "computing world." We at fischertechnik use the term "computing" to mean the programming and control of models using the PC. The ROBO Starter Set is the optimal entry into this subject. Using the assembly instructions, you can build eight different models in a short time and these models range from a handdryer to a bar barrier for entry into parking garages on to a welding robot. Using an interface such as the ROBO I/O-Extension, you can connect the models with the PC. (Note! You can also use the ROBO interface, item No. 93293.) Then, you program the models quickly and simply with the graphic programming software, ROBO Pro.



The following introduction is intended to help you to quickly find your way around in the computing world. Initially, this shows you how you should start and what you must do step by step. In addition, here you find programming tasks for all models in the building set. Of course, there are tips here for these tasks as well. You are given an exact description as to how you can program the models with the ROBO Pro software. As you will see, this is really great fun. So, let's go.

Before you get started Assembly

■ What do you really find in the building set?

First, you will find several fischertechnik building blocks, a motor, lights and sensors as well as colored construction instructions for the building of eight different models. Let's look at this first.

When you have unpacked all of the building blocks, you have to assemble some components first such as cables and plugs before you can really get started. The exact ones are described in the construction instructions in the paragraph "Assembly Help and Instructions." It is best to do this first.

Important Components

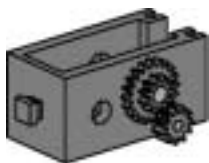

Motor

This motor drives the fischertechnik models. The motor is operated with a voltage of 9 volts --- (direct current). The maximum output is about 1.1 watt with a speed of 7000 revolutions per minute (RPM).

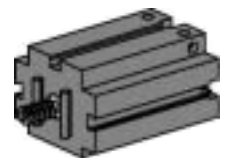

Gear unit

A gear unit is attached to the motor and this unit reduces the RPM.

The reduction is, including the motor worm gear and the toothed gear with the output shaft 64.8 : 1.

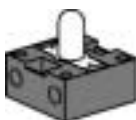

The building set contains two different lights:

Domed Light

This is a normal light bulb for a voltage of 9V --- and a power consumption of about 0.1 ampere (A).

Lens Tip Bulb

A lens is a part of this light bulb and this focuses the light. It looks very much like the domed light so that you have to watch out and don't mistake these. To make it easier to see the difference, the plug base for this bulb is gray, but the domed light has a white plug base. You need the lens tip bulb to build a light barrier. Technical data: 9V --- , 0.15A

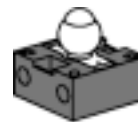

Phototransistor

You can also call the phototransistor a "brightness sensor." This is a "detector" that reacts to brightness. For a light barrier this is the counterpart to the lens tip bulb. When there is a high degree of brightness, that is when the transistor receives light from the lens tip bulb, it conducts electricity. If the light beam is interrupted, the transistor does not conduct any electricity.

Caution: When connecting the phototransistor to the power supply, you must pay special attention to the right pole: red = plus.

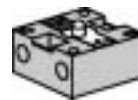

Sensing Device

The sensing device is also called a touch sensor. When you press the red button, this moves a switch mechanically and electricity flows between the contacts 1 (center contact) and 3. At the same time, the contact between the connections 1 and 2 is interrupted. So you can use the sensing device in two different ways:



As a "closer"

Contacts 1 and 3 are connected.

When the button is pressed electricity flows.

When the button is not pressed, no electricity flows.

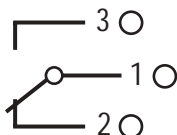

As a "opener"

Contacts 1 and 2 are connected.

When the button is pressed no electricity flows.

When the button is not pressed, electricity flows.

NTC Resistor



This component is a heat sensor that you can use to measure temperatures. At 20°C, the resistance is 1.5k Ω (kilo ohms). NTC stands for Negative Temperature Coefficient. This simply means that the resistance value decreases when the temperature increases.

The information, which the sensors supply to us such as bright-dark, pressed-not pressed, and temperature value, can be, as you will see later, passed to the PC through the interface and then with the help of the software, for example, you can program a motor to open a door as soon as the light barrier is interrupted.

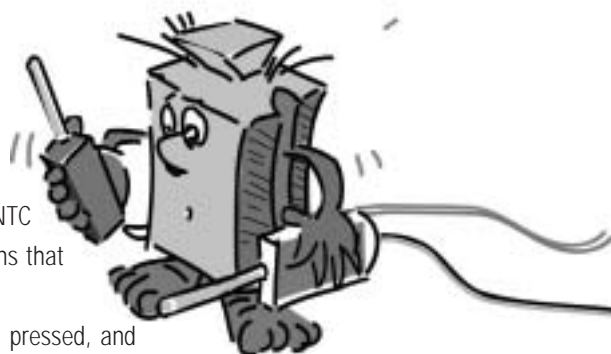

Interface and Software



■ Before you start to build models and create programs, you must install the ROBO Pro control software on your PC and then connect the interface, ROBO I/O extension, to your computer through the USB interface.

How to do this is described in detail in the ROBO Pro handbook in chapters 1 and 2. Follow these instructions exactly now and you should not have any trouble to get the software and the ROBO I/O-Extension to run. When the ROBO I/O extension is connected to the PC for the first time, then the associated USB driver must be installed. This works just like for the ROBO interface and is described in the handbook for the ROBO Pro software in chapter 1.2.

For the ROBO I/O-Extension you need a fischertechnik power supply with a voltage of 9V $\overline{---}$ and a current of 1000mA such as the Energy Set or the Accu Set. Now, we wish you a lot of success with the installation and the connection of the software and the interface. After this, we will continue here.

Your first programming steps

■ Now that the hardware and software are working, you can finally start with the programming. For this, we also need to use the ROBO Pro handbook again. There is no better way to start with programming than is described there in chapters 3 and 4. That's why we go back to this at this point. Work through both of these chapters carefully.

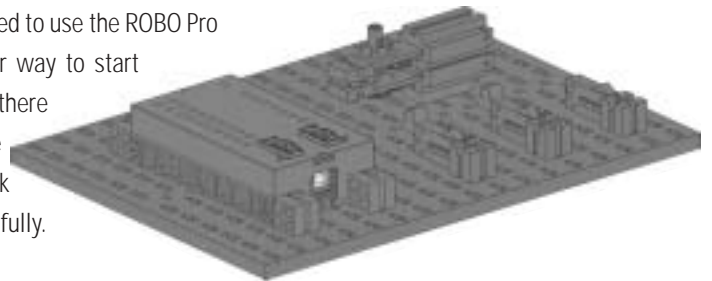

To test the first control program, which you have developed there, you can use the "motor control" model from the Computing Starter building set.

Build this model using the construction instructions and test your first program with this.



■ After you have read through chapters 3 and 4 of the ROBO Pro handbook, you can now program some models from the Computing Starter building set. So, that's why we want to start right away. Every time when you have finished building a model and attached the wiring, you need to conduct a check using the interface test to determine if all outputs and inputs are correctly connected to the interface and the sensors, motors and lights are working properly.

■ In your school in the bathroom, new handdryers were installed beside the wash basins. These have a light barrier, which allows you to turn on and turn off the blower. First, build the model as described in the construction instructions.

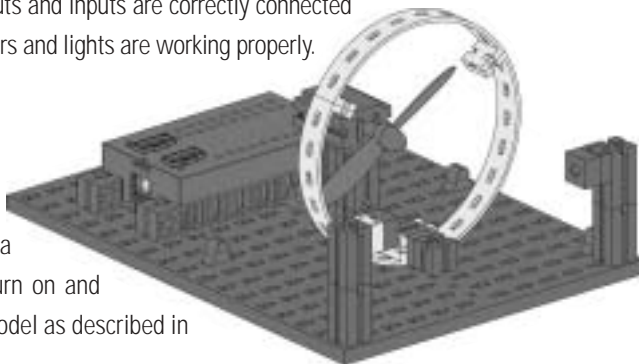

Task 1:

The handdryer is to be programmed so that as soon as the light barrier is interrupted, the blower is to be turned on and then after five seconds it is to be turned off.

Programming Tips:

- First, in the program sequence, turn on the light for the light barrier at output M2. After this, wait a second so that the phototransistor has time to react to the light. Only then will the light barrier work properly.
- Then you interrogate the phototransistor on input I1. If the value is 1 (light barrier not interrupted) then the input is to be interrogated continuously in a loop.
- As soon as the value changes to 0 (light barrier interrupted), turn on the motor, M1, and then turn it off after five seconds.
- Following this, the phototransistor is to be interrogated again and so forth.

Start your program with the start button and check to see if it is working as desired. If it does work right, then you're on the right path to become a professional ROBO Pro programmer.

If it doesn't work, try to find out why:

- With the interface test, you can check to see if all inputs and outputs are working and correctly connected.
- While the program is running, you can follow the program flow with the red building blocks. This allows you to quickly see where an error has crept in.
- Finally, you can compare your program with the complete sample program, Handdryer 1.rpp, which is found in the directory C:\Programs\ROBO Pro\SamplePrograms\ROBO Starter or C:\Programs\ROBO Pro\SamplePrograms\Computing Starter.

Now that you have taken this hurdle, we want to change the task a bit.

Programming Tasks Part 1

Handdryer

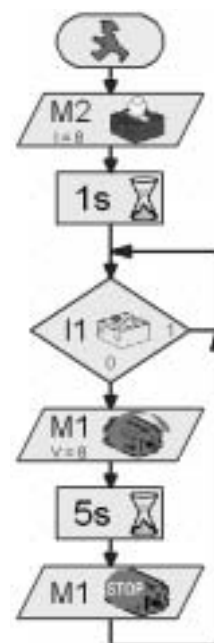

Task 2:

The school principal, who is always interested in saving energy, doesn't like it when the handdryer continues to run for a time even if your hands are already dry. He asks you to design the program so that the blower is shutoff as soon as your hands are pulled back. That's not a problem for you, or?

**Programing Tips:**

- As in the first program, you interrogate the phototransistor I1 with a branch. If the value is 0, then turn the motor, M1, on and when the value is 1 then turn the motor, M1, off and so forth.
- For this task, there is also a complete program, Handdryer 2.rpp, in case it is needed.

Traffic Light

■ A traffic light was put up in front of your house. Since the installer from the stop light company was under a lot of time pressure, you offer to do the programing for the control of the stop light for him. The man explains to you how the control is supposed to work. But first, build the model.

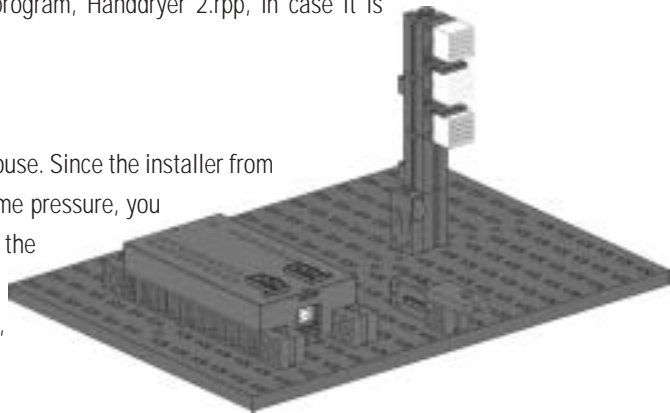
**Task 1:**

- Normally, the traffic light is to be green.
- If the button I1 is pressed by a pedestrian then the traffic light is to change to yellow three seconds later and after an additional four seconds to red.
- The red phase is to last 10 seconds followed by the red-yellow phase for three seconds.
- Then it is to go back to green.

**Programing Tips:**

- The various indicator lights belong to the following interface outputs:
Red: M1
Yellow: M2
Green: M3
- Turn the lights on and off one after the other so that the desired sequence is achieved.
- Sample Program: C:\Programs\RoboPro\SamplePrograms\ROBO Starter \Traffic light 1.rpp or
C:\Programs\RoboPro\SamplePrograms\Computing Starter \Traffic light 1.rpp

Task 2:

On the next day, the installer from the traffic light company calls you up:

He forgot to tell you that in the control cabinet on the sidewalk, there is a switch, I2, which switches the traffic light to blinking yellow when it is activated.

You tell the installer that you will integrate this function into your program quickly.

**Programing Tips:**

- Using an additional branch, interrogate the input, I2. If the button, I2, is pressed, the sequence branches to the blinking light. Otherwise, the control of the stop light runs as in task 1.
- You get the blinking light by turning the indicator light, M2, on and off with a time interval of 0.5 seconds. Use a subprogram to do this. You can find out how to make a subprogram in chapter 4 of the ROBO Pro Handbook.
- Sample Program: Stop light2.rpp.
But before you look, try to find the solution on your own. Good Luck!

■ The supermarket, where you help out by the hour to fill the shelves, has got a new entrance door. But the control software has to be created for this door. The store manager knows that you are an expert in programing and asks you to take care of that. But first, build the model.

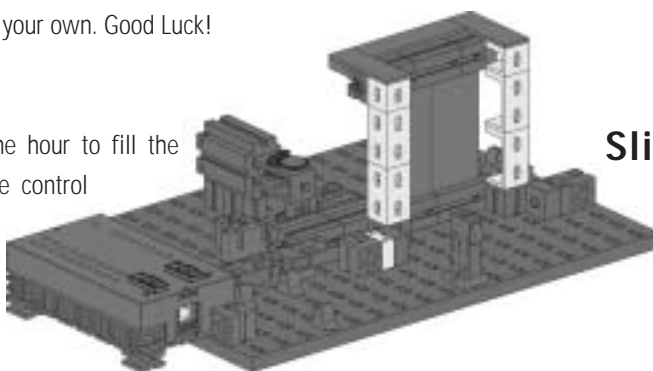
**Sliding Door****Task 1:**

When the button I3 is pressed, the door is supposed to open and after five seconds it is to close again.

Programing Tips:

- First, close the door. It is now in the starting position.
- Then, interrogate the button, I3. If it is pushed, the door is supposed to open.
- After five seconds, close the door.
- Sample Program: Sliding door 1.rpp

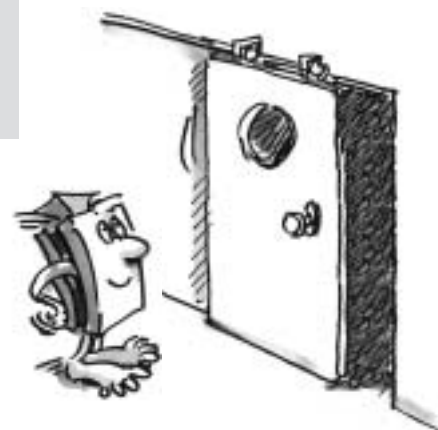



Task 2:

Your door control works great. However, when the first customer caught his leg in the door because he tried to go through the door right at that time that it was being closed, you decide to improve the program a little. The door has a light barrier, which is supposed to prevent the door from closing when someone is going through it. You want to expand the program so that the

1. door will only be closed when the light barrier is not interrupted;
2. door opens when the light barrier is interrupted when the door is being closed;
3. door opens when it is closed without having to press the button as soon as the light barrier is interrupted.



Programming Tips:

- First, just as you did before for the handdryer, switch on the light for the light barrier and wait a second before the sequence goes further.
- Wherever it is necessary, query the phototransistor and open the door when the phototransistor displays the value 0.
- Completed project, sliding door 2.rpp.



Finished! Your boss is proud of you! The door works perfectly and is absolutely safe.

■ Before you move on to the second part of the programming tasks, you should go back to the ROBO Pro handbook.

Work through chapter 5 carefully in the handbook. Switch to level 3 in ROBO Pro.

The programming tasks are slowly becoming more demanding. We will use analog inputs, operating elements, operators and variables.

However, if you read the ROBO Pro handbook attentively, you will find it easier to use later.

■ At home where you live, a new air conditioning system was installed. Of course, you immediately asked the installer how the temperature control works.

He was happy to explain to you that a temperature sensor continually measures the temperature. As soon as a maximum value is exceeded, the air conditioning is turned on.

However, on the other hand, if the temperature is below the minimum value, the air conditioning is turned off and the heating is turned on. Now, using the "temperature control" model, you also want to try to program such a control circuit. But first, build the model.

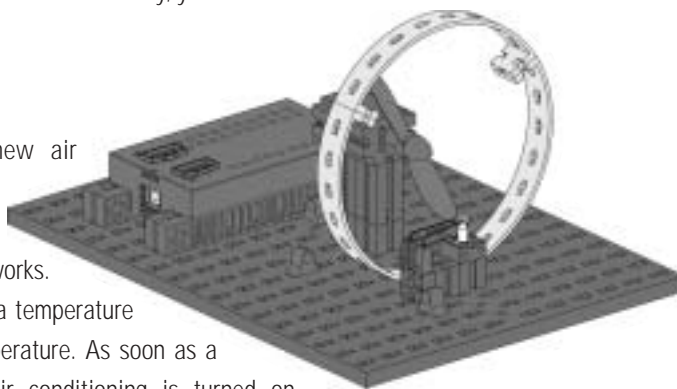

Programming Tasks Part 2

Temperature Control

Task:

- The heating is simulated by the lens tip bulb, M2.
- The blower on output, M1, serves as the "cooling unit."
- To measure the temperature, we will use the NTC resistor at the input, AX.
- Program the model so that above a certain temperature, the heating is shut off and the blower is turned on. This is to cool until a minimum value is reached. Then the blower is to be shut off and the heating is to be turned on.
- The current value for the analog input is to be outputted to a measuring device and a text display.



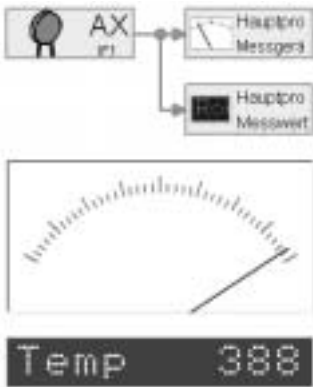

Programing Tips:

- Please note! The resistance value of the NTC resistor decreases with increasing temperature. Therefore, the maximum temperature value is the smallest value for AX. At this limit value, the blower is to be turned. The lower temperature limit is the biggest value for AX. At this limit value, the heating is to be turned.
- With the interface test, you can find out what value AX has at room temperature. Turn on the indicator light, M2, and observe how much the value decreases. Now turn on the blower and find out how much the value increases. Based on this, select the limit values for heating and cooling.
- Display the value of the analog input in your program with the display of a text and/or with a measuring instrument (see ROBO Pro Handbook chapter 8.1).
- Sample program: Temperature control.rpp

Stamping Press

■ The shop next door has invested in a very modern machine for the punching of sheet metal parts. The machine has been set up already. Unfortunately, the programmer, who was to place the system in operation, will not arrive until two weeks from now. Since the shop urgently needs the machine, the owner asks you if you would be able to make the machine run. Since, in the meantime, you have gathered quite a lot of experience in programming, you promise him to have the system running by tomorrow. First, build the model stamping press using the construction instructions.

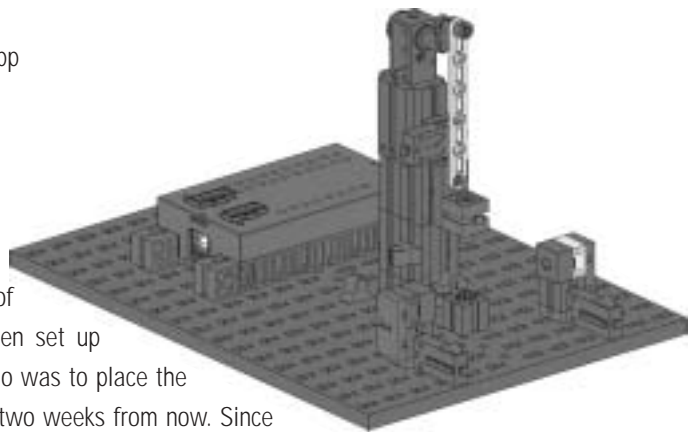

Task 1:

- The machine is to punch a part in one working cycle with four strokes.
- The machine may only start when the operator pushes both buttons I3 and I4 (two-hand operation) and the light barrier is not interrupted.
- If the light barrier is interrupted during the working cycle, the machines stops.

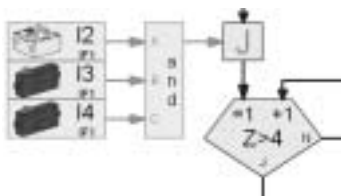

Programing Tips:

- To interrogate the inputs I2 (light barrier) and I3 and I4 (buttons) at the same time, use the orange input elements and an AND link (see ROBO Pro Handbook chapter 5.7).
- To count the four strokes, use the counter loop element.
- Sample program: Stamping press 1.rpp

**Task 2:**

To really impress the shop owner, you expand the program so that you can set the number of strokes for one working cycle with a slider control and can also display the number of parts produced.

Programing Tips:

- Using variables, you count the strokes and the parts produced.
- Under the control elements, which are described in the ROBO Pro Handbook in chapter 8, you can find the slider control to set the number of strokes.
- Sample program: Stamping press 2.rpp

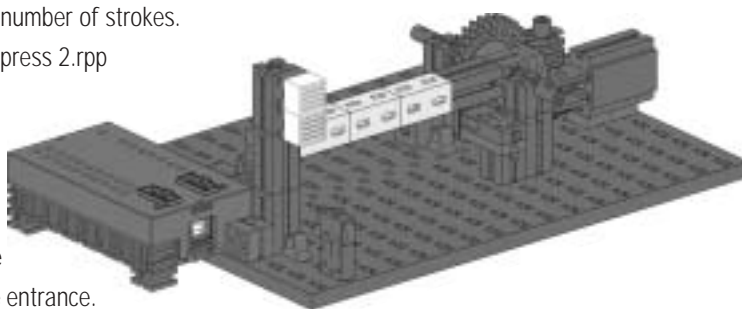
**Car Park Barrier**

■ Next Saturday, the new parking garage is to be opened in the city. Today, the bar barrier was installed in the entrance.

Since in the meantime, it is well known that you are the best programmer in the city, they asked you to do the programming. Of course, you are proud of this and start work on this right away. Set up the model.

Task 1:

- The bar barrier is to be opened by pressing the button, I3.
- When the bar barrier is raised, the light goes green.
- When the light barrier has been passed, the light goes to red and the bar barrier is lowered.

**Programing Tips:**

- To open and close the bar barrier, write a subprogram "open" and a subprogram "close."
- In the program sequence, first switch the light for the light barrier on (M4) and then switch the traffic light to red (M2).

Task 2:

- On the opening day, the parking garage is to be kept free for prominent guests.
- For this purpose, those who are to be allowed to park are to receive a secret number combination with three digits.
- The bar is only to be raised when the correct code is entered.
- The numbers are to be entered using an operator's console.
- The numbers 1 to 6 are available for selection. The right code is 352.



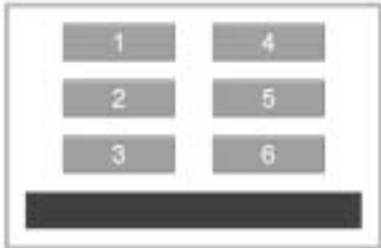

Programing Tips:

- It is best to use a separate subprogram for the code lock.
- Chapter 5.7 of the ROBO Pro handbook describes some possibilities for the construction of a code lock.
- The code is entered using six buttons.
- Using a command, "Text," and a display element you can output a message to show if the code entered was right or wrong.
- Sample program: Car park barrier 2.rpp

Welding Robot

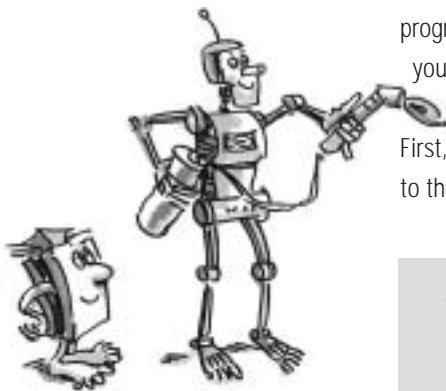

■ The shop, which was mentioned before, has also purchased another welding robot. Since the owner was amazed at how you recently programed his punch press, he asks you if you would place his welding robot in operation. First, set up the model according to the construction instructions.

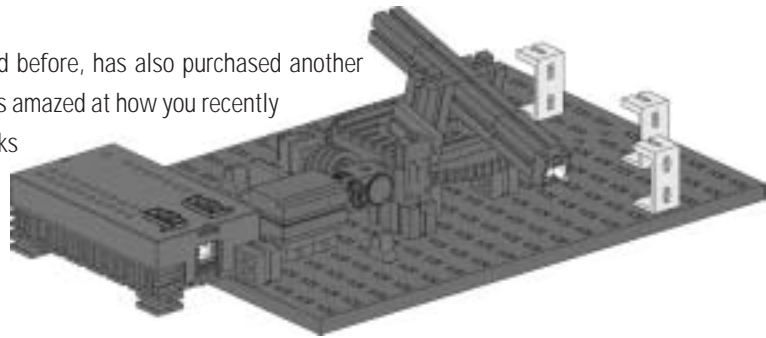

Task:

- The robot is to attach a cover to a metal housing with a spot weld at a different position for each metal housing in a set of three metal housings.
- The welding rod is simulated by a lens tip light and the three metal housings by yellow building blocks.
- The robot is to move to the three positions one after the other and make a spot weld at each position.
- Then, it is to return to its starting position and start from the beginning again.

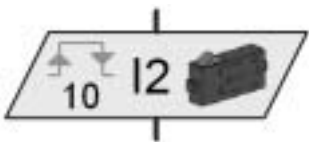

Impuls counter

Programing Tips:

- First, move the robot to its starting position.
- To move to the various positions, you use the element, impulse counter.
- Just experiment to find out how many impulses are needed for what position.
- For the welding process, you use a subprogram, in which you make the indicator light blink several times.
- Sample program: Welding robot.rpp

■ With a little bit of fantasy, you can certainly develop additional tasks for the models from the ROBO Starter building set and write the programs for these. For example, the welding robot could make a spot weld at a fourth position or the robot could move to these three positions in another sequence several times. With some additional components, you could expand the stop light to cover an entire street intersection with extensive traffic light controls. Just give yourself time to think because there are certainly lots of further possibilities.

■ All program and operating elements are described in chapters 7 and 8 of the ROBO Pro handbook. These chapters are very useful as references. It's worth reading!

■ There are also additional computing building sets from fischertechnik. The ROBO Mobile Set contains seven mobile robots and a crawler robot. You can program these so that they can avoid obstacles or do not fall off the table.

■ With the building set, Industry Robots II, the things you can build include a grab robot with three axes of movement that can be easily controlled with the mouse through a teach-in program. When this is done, the robot remembers the positions and can automatically repeat the stored sequence.

■ The models in the building set, ROBO Starter, can also be operated with the ROBO interface. This has its own memory and you can load the ROBO Pro programs into this memory so that the model works independently of the PC. The ROBO I/O extension can also be connected to this interface as an expansion module. This allows the number of inputs and outputs to be increased for the ROBO interface. A total of up to three ROBO I/O extensions may be connected to a ROBO interface.

■ In addition, with the help of the ROBO RF Data Link the ROBO interface can communicate by radio transmission with a PC or other ROBO interfaces. This is especially interesting for mobile models that can then play, for example, soccer with each other.

■ Of course the models from various building sets can be combined and this creates new extensive models and programming tasks. The possibilities of the fischertechnik computing system are almost unlimited.

What else can you do?

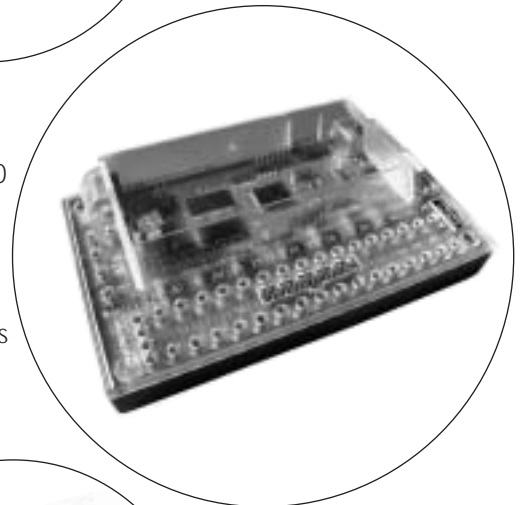
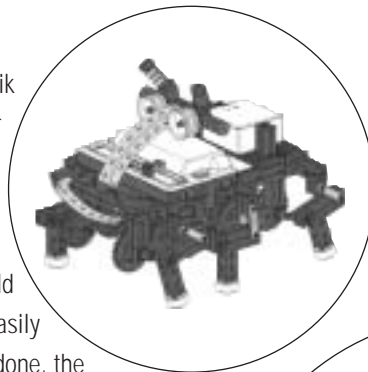



A series of horizontal dotted lines for writing, extending across the width of the page.