

536632

Multi Processing Station with Oven 24V

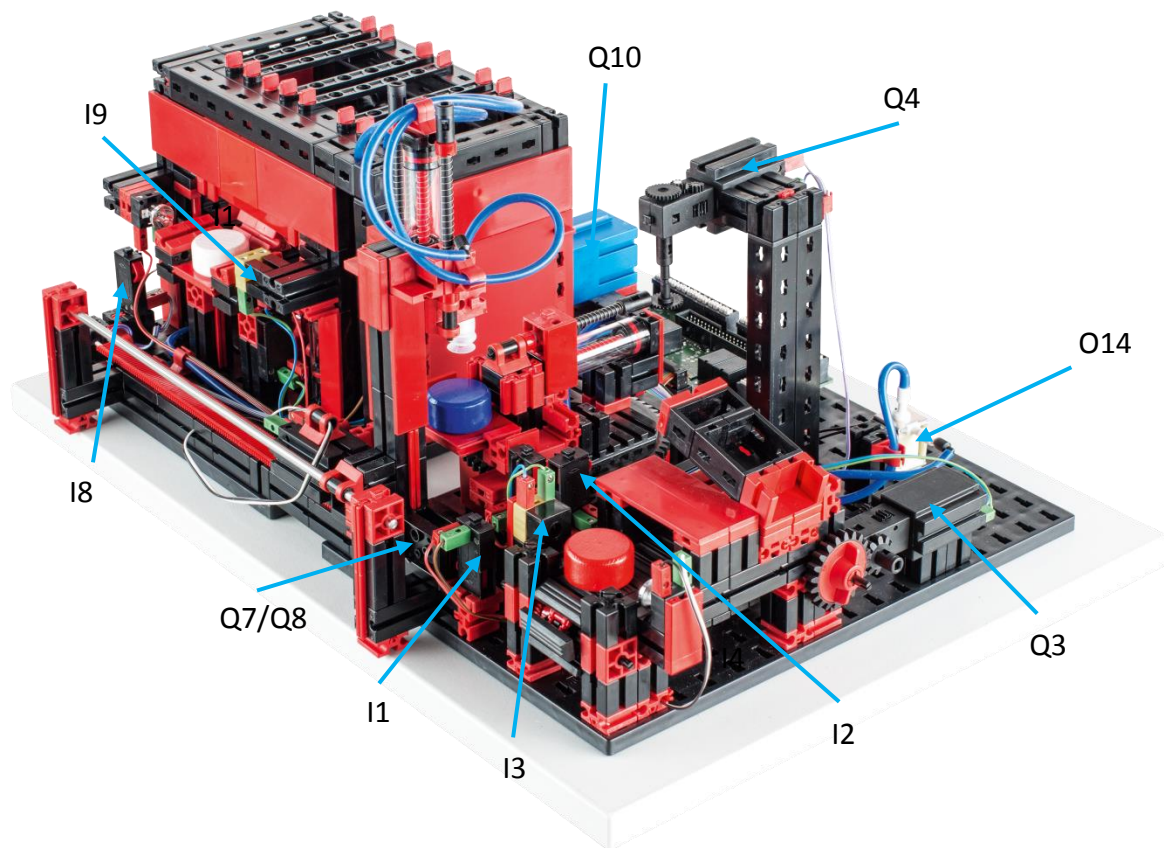

not in the picture: Q1, Q2, Q5, Q6, Q9, Q11, Q12, Q13, I4, I5, I6, I7

Circuit layout of the Multi Processing Station with Oven

| Terminal no. | Function | Input/Output |
|--------------|---|--------------|
| 1 | power supply (+) actuators | 24V DC |
| 2 | power supply (+) sensors | 24V DC |
| 3 | power supply (-) | 0V |
| 4 | power supply (-) | 0V |
| 5 | reference switch turn-table (position vacuum) | I1 |
| 6 | reference switch turn-table (position belt) | I2 |
| 7 | light-barrier end of conveyor belt | I3 |
| 8 | reference switch turn-table (position saw) | I4 |
| 9 | reference switch vacuum (position turn-table) | I5 |
| 10 | reference switch oven feeder inside | I6 |
| 11 | reference switch oven feeder outside | I7 |
| 12 | reference switch vacuum (position oven) | I8 |
| 13 | light-barrier oven | I9 |
| 17 | motor turn-table counterclockwise | Q1 (M1) |
| 18 | motor turn-table counterclockwise | Q2 (M1) |
| 19 | motor conveyor belt forward | Q3 (M2) |
| 20 | motor saw | Q4 (M3) |
| 21 | motor oven feeder retract | Q5 (M4) |
| 22 | motor oven feeder extend | Q6 (M4) |
| 23 | motor vacuum towards oven | Q7 (M5) |
| 24 | motor vacuum towards turn-table | Q8 (M5) |
| 25 | light oven | Q9 |
| 26 | Compressor | Q10 |
| 27 | valve vacuum | Q11 |
| 28 | valve lowering | Q12 |
| 29 | valve oven door | Q13 |
| 30 | valve feeder | Q14 |

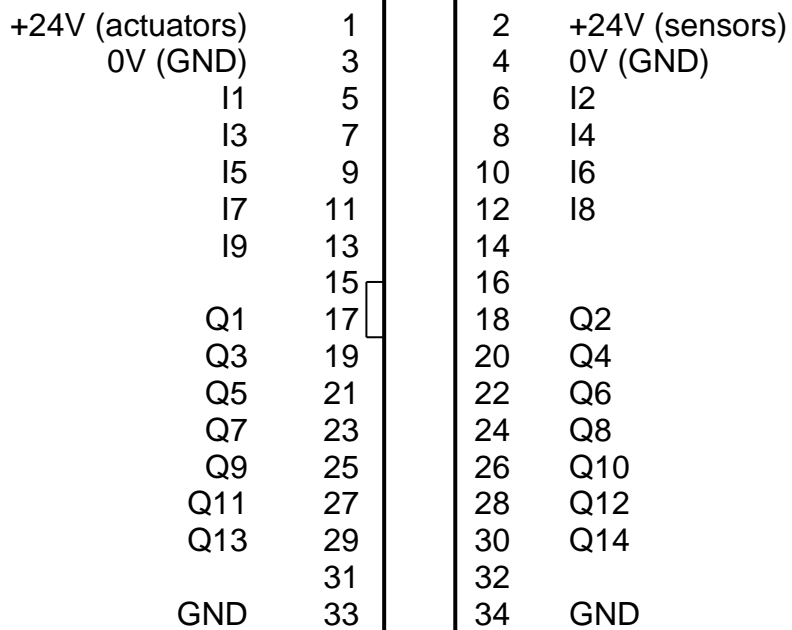

PLC input and output configuration

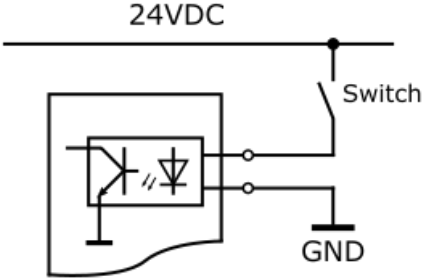
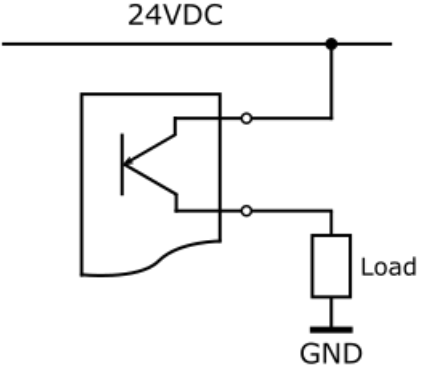
| | Inputs | Outputs |
|-----------|---|--|
| Type | Sinking input | Sourcing output |
| Switching |  |  |

Technical data:

S motor:

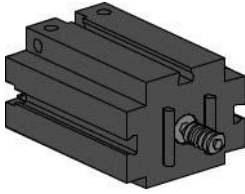

The high-bay rack feeder boom is powered by an S motor. This compact motor is a permanent magnet DC motor that can be used together with an attachable motor reducing gearbox. The motor is operated at a rated voltage of 24V DC and the maximum current input is 300 mA. The result is a maximum torque of 5 mNm and an idling speed of 10,700 rpm. The motor reducing gearbox has a gear ratio of 64.8:1 and a lateral output.

Phototransistor:



Phototransistors are used as light barriers for the multi processing station with oven. In the process, the phototransistor conducts electricity from a certain level of brightness. However, if this luminescence threshold is exceeded, the phototransistor loses its conductivity. Together with a lens tip lamp, which faces the phototransistor, the phototransistor usually conducts electricity and can thus be used as a light barrier. A stray light hood can be used to reduce the effects of ambient light.

Caution: When connecting the phototransistor to the power supply, make sure the polarity is correct. Connect the positive pole at the red marking on the phototransistor.

Mini-switch:

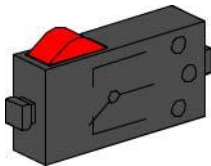

For the sorting line with detection, the mini-switch is used as a pulse counter. Combined with a pulse wheel, the push-button switches are used as incremental rotary encoders to determine the position of the conveyor belt. The mini-switch used in this case can be used both as a normally closed contact and as a normally open contact. When the switch is actuated, equipotential bonding occurs between contact 1 and contact 3, while the connection between contact 1 and contact 2 is separated.

Figure 1 shows the schematic circuit diagram of the mini-switch.

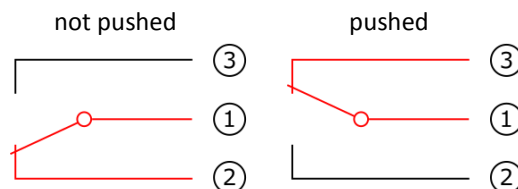
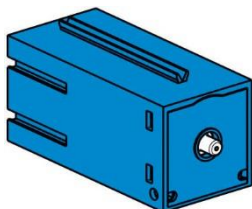

Fig. 1: Mini-switch circuit diagram

Compressor:



A diaphragm pump supplies compressed air to the vacuum gripper robot. This type of diaphragm pump consists of two chambers separated by a

diaphragm; see Figure 2. A cam moves a piston in one of the two chambers up and down, causing the air in the other chamber to be drawn in or pressed out. During the downward stroke the diaphragm is pulled back, causing air to be pulled into the second chamber through the inlet valve. When the piston moves up, the diaphragm presses the air out of the pump head through the outlet valve. The compressor used in this case has a rated voltage of 9 V and produces an overpressure of 0.8 bar. The maximum current input of the compressor is 200 mA.

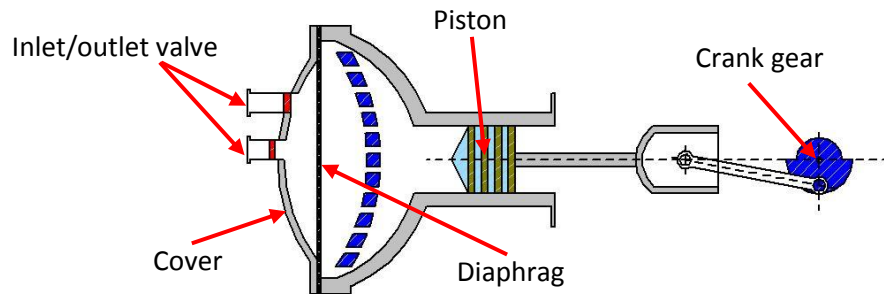
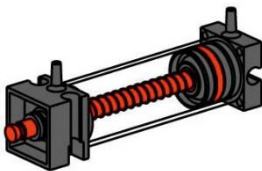

Fig 2: Schematic drawing of the diaphragm pump

Pneumatic cylinders:



Two pneumatic cylinders handle the suction function of the vacuum gripper robot and are controlled with the help of a 3/2 way solenoid valve. In the case of the pneumatic cylinders, a piston divides the volume of the cylinder into two chambers. Differing pressure between these two chambers results in force placed on the piston, causing the piston to move. This movement corresponds to a change in volume in both chambers. Two cylinders are then mechanically connected in order to create a vacuum, which is pressure that is lower than the ambient pressure, in the vacuum gripper robot. If a cylinder is then supplied with excess pressure, the two piston rods extend, causing the volume to increase in the chamber closed by the suction cup. This increase in volume is accompanied by a drop in pressure in this chamber.



3/2 way solenoid valve:

3/2 way solenoid valves are used to control the pneumatic cylinders. These control valves have three connection points and two control states. The switching operations are carried out by a solenoid coil (a), which operates against a spring (c). When voltage is applied to the solenoid, the movable core (b) of the coil moves against the spring as a result of Lorentz force, causing the valve to open. Open in this case means that the compressed air connection (current description: 1, previous description: P) is connected with the cylinder connection (1, previously A). If this voltage drops, the spring pushes the core back again, causing the valve to close again. In this position, the cylinder connection (2, previously A) is connected with the air vent (3, previously R). Figure 3 shows a schematic drawing of the 3/2 way solenoid valve. The solenoid valve connection is made using two cables: one connected to the PLC output and the other connected to ground.

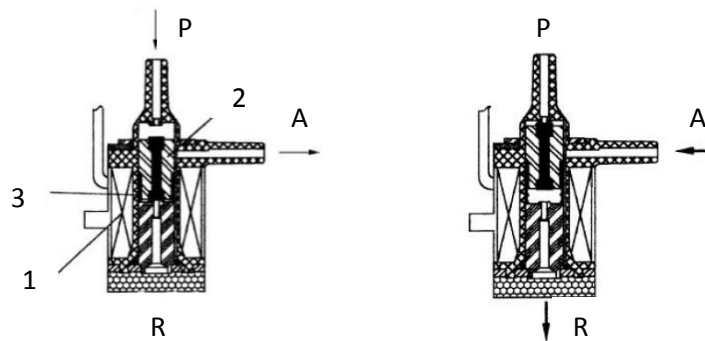

Fig. 3: 3/2 way solenoid valve

Multi processing station with oven

In the case of the multi processing station with oven, the workpiece automatically runs through several stations that simulate different processes. These processes use different conveyor systems, such as a conveyor belt, a turntable and a vacuum gripper robot. Processing begins with the oven. To start processing, the workpiece is placed on the kiln feeder. The light barrier is interrupted when this happens, opening the oven door and drawing in the kiln feeder. At the same time, the vacuum gripper is called, which brings the workpiece to the turntable after the firing process. Following the firing process, the kiln feeder moves outward again. The pre-positioned vacuum gripper picks up the workpiece, transports it to the turntable and sets it down there. The turntable positions the workpiece under the saw, waits there while the workpiece is processed and then carries the workpiece to the pneumatically operated ejector. The ejector slides the workpiece onto the conveyor belt, which conveys the workpiece to a light barrier and then ejects it. Crossing the light barrier causes the turntable to return to its starting position and the conveyor belt to come to a delayed stop.

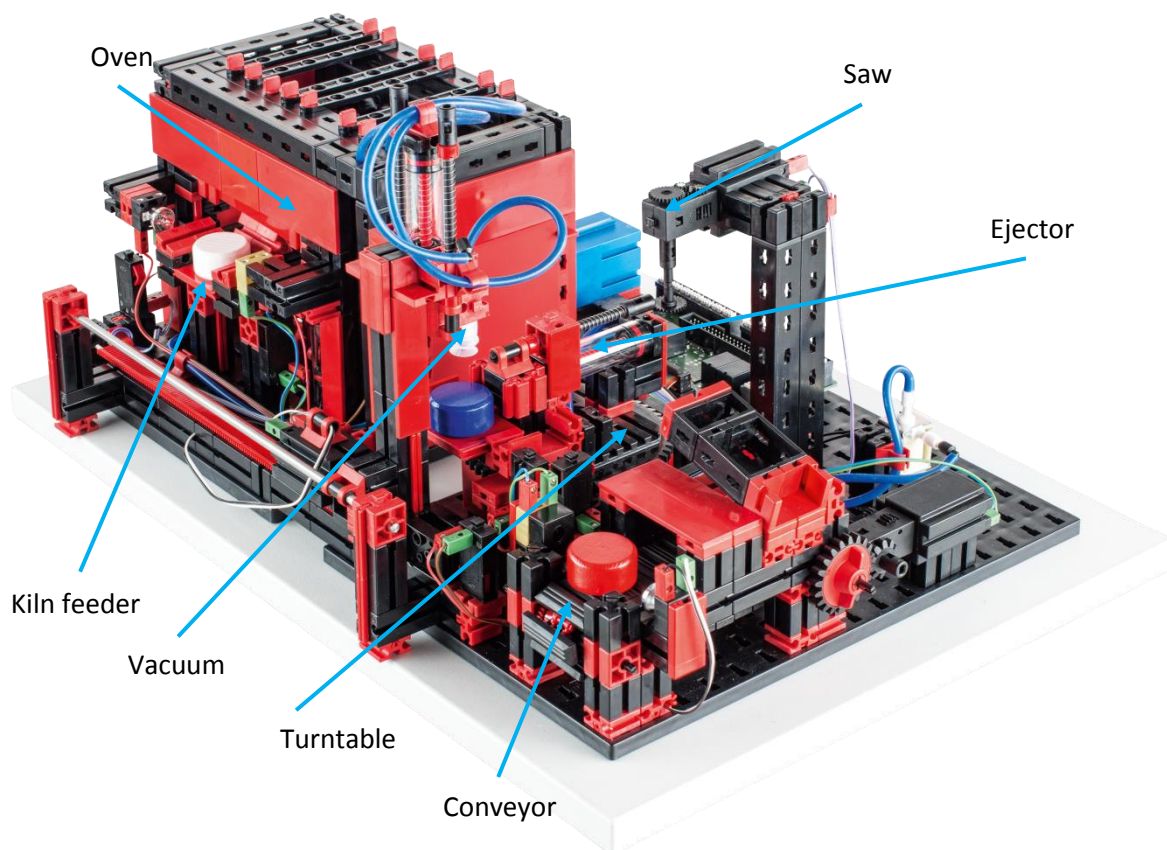

Fig. 1: Areas of the multi processing station with oven

The multi processing station with oven is controlled by two TXT controllers, which operate in an integrated master-extension setup. The second controller serves as the extension, where the master controller can control a total of 16 universal inputs, eight fast counter inputs and eight motor outputs. Due to the large number of inputs and outputs, the programs run in parallel. The system is divided into three parts: the oven, vacuum gripper robot and turntable. The particular processes communicate with each other, thereby ensuring among other things that no collisions occur. For

instance, the oven triggers movement of the vacuum gripper robot at two locations of the programming sequence, ensuring that the vacuum gripper robot is positioned at the right location when needed while also ensuring that there is something for the gripper to grasp at the location. Likewise, the turntable is activated by the vacuum gripper robot after the workpiece is set down.

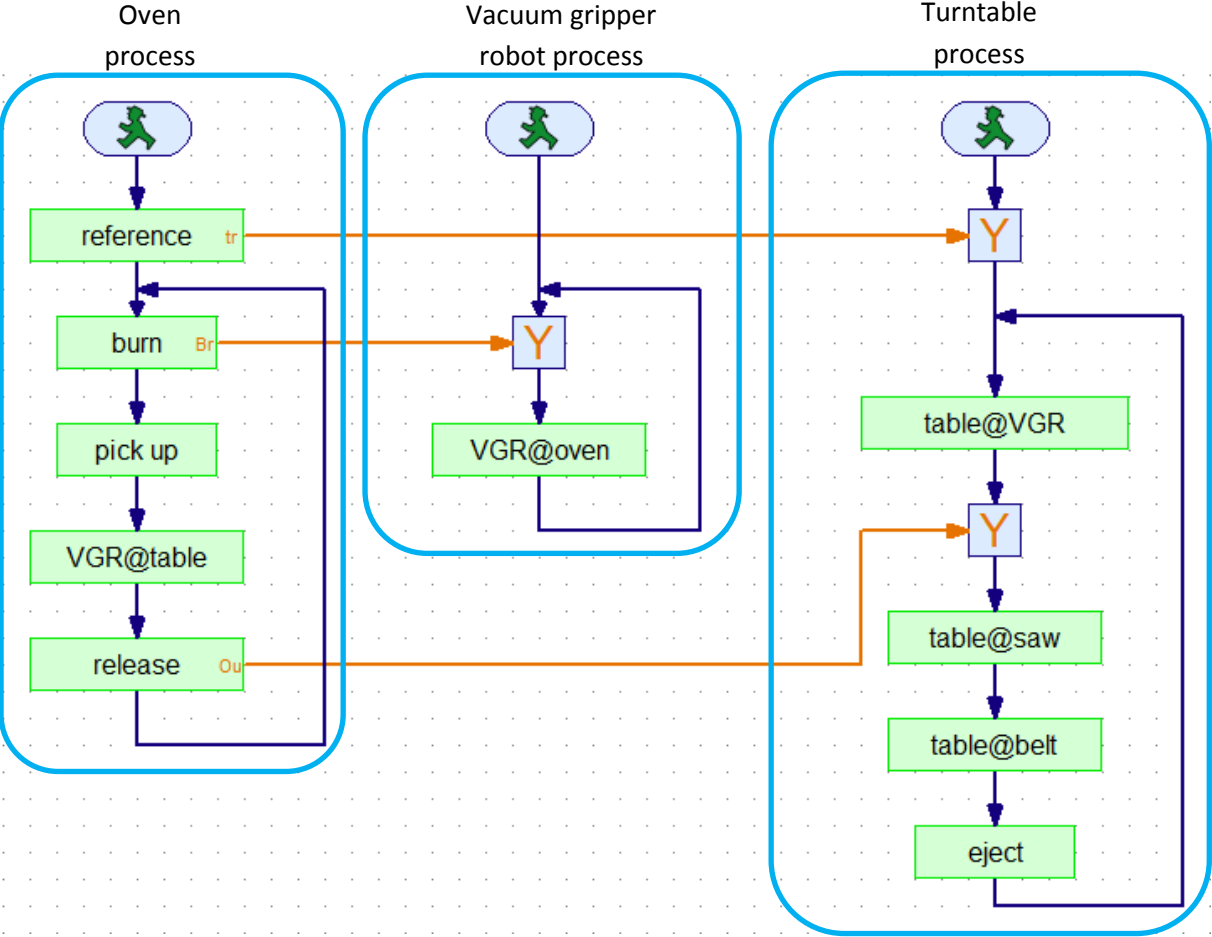
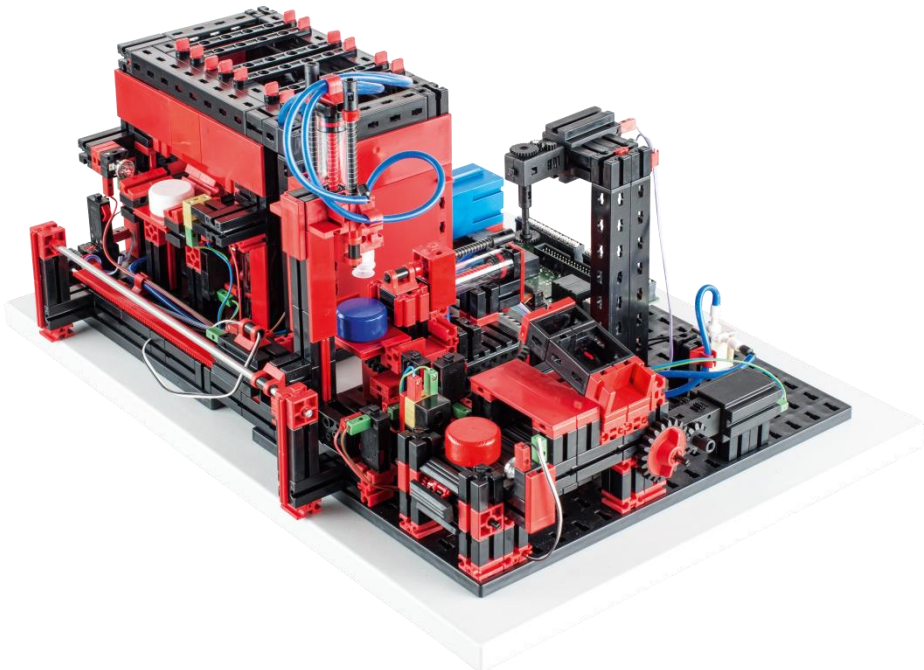

Fig. 2: Program areas of the multi processing station with oven

Multi processing station with oven

Identify the “oven”, “vacuum gripper robot”, “turntable” and “conveyor belt” components.



Which three conveyor systems are used with the multi processing station with oven?

Multi processing station with oven

ANSWER

Identify the “oven”, “vacuum gripper robot”, “turntable” and “conveyor belt” components.

1. *Oven*
2. *Vacuum gripper robot*
3. *Turntable*
4. *Conveyor belt*

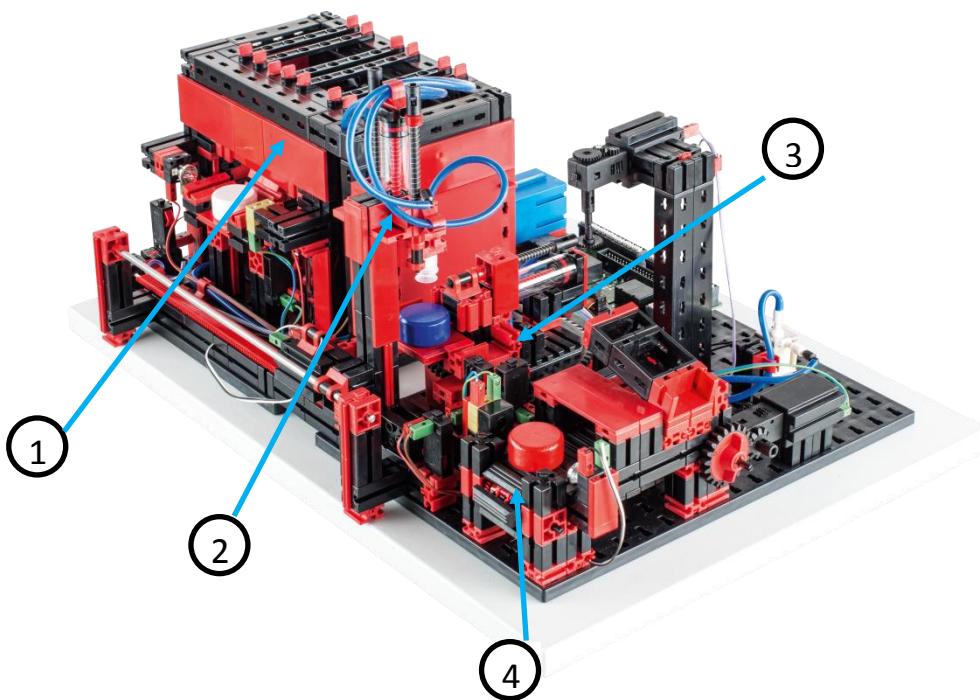

Which three conveyor systems are used with the multi processing station with oven?

- Conveyor belt*
- Turntable*
- Vacuum gripper robot*

Maintenance and troubleshooting

The multi processing station with oven is generally maintenance free.

Problem: **The vacuum gripper robot loses workpieces during transport.**

Solution: Make sure that the hose connection (Art. No. 35328) end is flush with the top edge of the suction cup. Make sure that the surface of the workpiece is free of contaminants. It may help to moisten the vacuum gripper robot.

Problem: **The conveyor belt no longer stops.**

Solution: The conveyor belt stops with a delay when the workpiece passes the last light barrier.

Problem: **The light barrier on the oven does not detect that a workpiece is on the feeder.**

Solution: The light barrier detects that the workpiece has been set down, but does not detect the presence of the workpiece.

Problem: **The door of the oven does not open/close, or the workpiece is no longer pushed off the turntable.**

Solution: Verify that all pneumatic hoses are connected correctly and that the compressor is working properly.