

536625

**Vacuum Gripper Robot 9V**

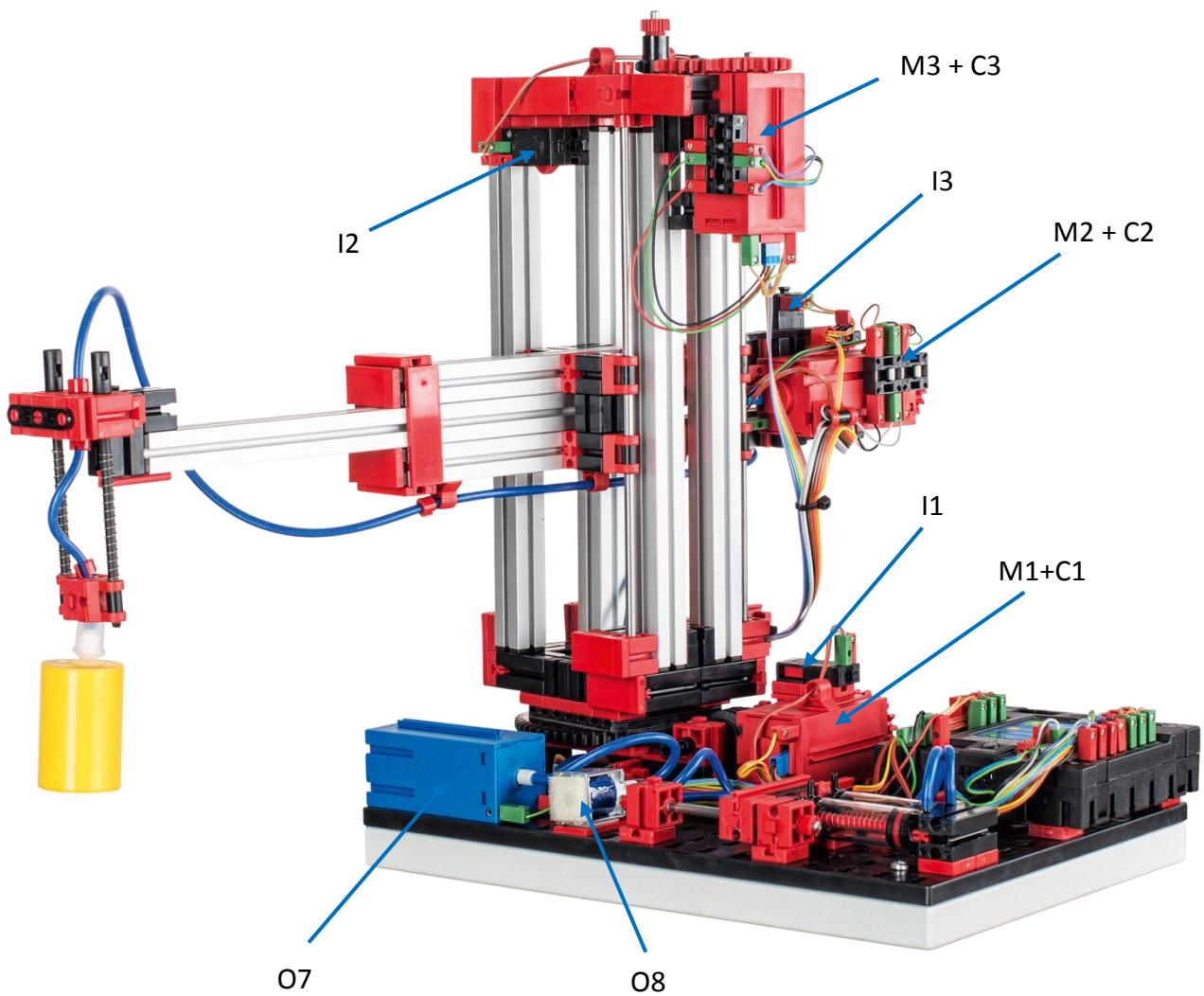

### Circuit layout of the Vacuum Gripper Robot

<b>Number</b>	<b>Function</b>	<b>Input/Output</b>
1	reference switch rotate	I1
2	reference switch vertical axis	I2
3	reference switch horizontal axis	I3
4	encoder rotate	C1
5	encoder vertical axis	C2
6	encoder horizontal axis	C3
7	motor rotate	M1
8	motor vertical axis	M2
9	motor horizontal axis	M3
10	compressor	O7
11	valve	O8

## Technical data

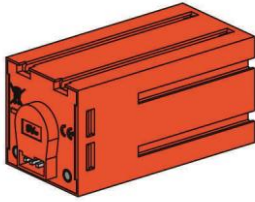

### Encoder motor:

The vacuum gripper robot is powered by three encoder motors. This is possible through permanent magnet DC motors, which enable the incremental measurement of angles with the help of Hall effect sensors. The encoder motors operate at a rated voltage of 9V DC and have a maximum output of 1.2 W at 105 rpm. The current input at maximum power is 386 mA. The integrated gearbox gear ratio is 21.1:1. This means that the encoder produces three pulses per motor shaft rotation or 63.3 pulses per rotation of the gearbox output shaft. Since only one pulse is indexed, the encoder used cannot distinguish the direction in which the motor is rotating.

The encoder is connected to the TXT controller via a triple core cable with a red wire for the 9 V output and a green wire for the ground connection. The black cable transmits the signal (NPN open collector output, 1 kHz max.) and needs to be connected to a fast counter input (C1-C4). If a fischertechnik controller will not be used to read out the encoder signal, the use of a pull-up resistor (4.7-10k $\Omega$ ) is required.

### Mini-switch:

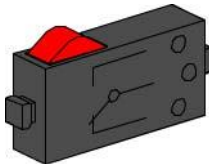

Mini-switches are used as reference switches for the vacuum gripper robot. When using incremental measuring methods, a reference switch is used to determine the absolute position or absolute angle. The mini-switch used for this purpose includes a changeover switch and can be used both as a normally closed contact and as a normally open contact. When the switch is actuated, equipotential bonding occurs between contact 1 and contact 3, while the connection between contact 1 and contact 2 is separated. Figure 1 shows the schematic circuit diagram of the mini-switch.

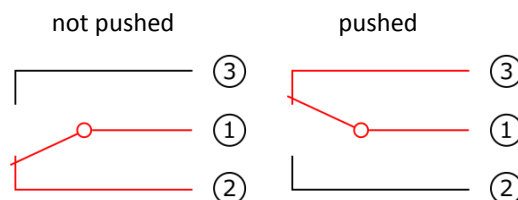
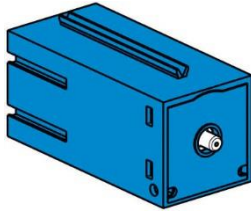

Fig. 1: Mini-switch circuit diagram

### Compressor:



A diaphragm pump supplies compressed air to the vacuum gripper robot. This type of diaphragm pump consists of two chambers separated by a diaphragm; see Figure 2. A cam moves a piston in one of the two chambers up and down, causing the air in the other chamber to be drawn in or pressed out. During the downward stroke the diaphragm is pulled back, causing air to be pulled into the second chamber through the inlet valve. When the piston moves up, the diaphragm presses the air out of the pump head through the outlet valve. The compressor used in this case operates at a rated voltage of 9V DC and produces an overpressure of approximately 0.7 bar. The maximum current input of the compressor is 200 mA.

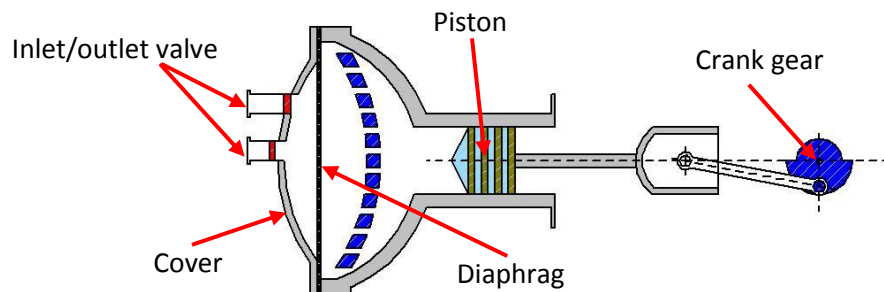
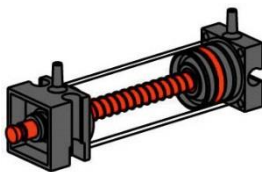

Fig 2: Schematic drawing of the diaphragm pump

### Pneumatic cylinders:



Two pneumatic cylinders handle the suction function of the vacuum gripper robot and are controlled with the help of a 3/2 way solenoid valve. In the case of the pneumatic cylinders, a piston divides the volume of the cylinder into two chambers. Differing pressure between these two chambers results in force placed on the piston, causing the piston to move. This movement corresponds to a change in volume in both chambers. Two cylinders are then mechanically connected in order to create a vacuum, which is pressure that is lower than the ambient pressure, in the vacuum gripper robot. If a cylinder is then supplied with excess pressure, the two piston rods extend, causing the volume to increase in the chamber closed by the suction cup. This increase in volume is accompanied by a drop in pressure in this chamber.



### 3/2 way solenoid valve:

3/2 way solenoid valves are used to control the pneumatic cylinders. These control valves have three connection points and two control states. The switching operations are carried out by a solenoid coil (a), which operates against a spring (c). When voltage is applied to the solenoid, the movable core (b) of the coil moves against the spring as a result of Lorentz force, causing the valve to open. Open in this case means that the compressed air connection (current description: 1, previous description: P) is connected with the cylinder connection (1, previously A). If this voltage drops, the spring pushes the core back again, causing the valve to close again. In this position, the cylinder connection (2, previously A) is connected with the air vent (3, previously R). Figure 3 shows a schematic drawing of the 3/2 way solenoid valve.

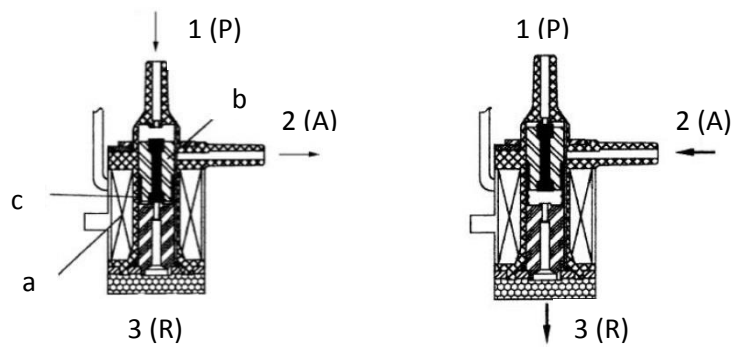

Fig. 3: 3/2 way solenoid valve

## What are robots?

The Society of German Engineers (VDI) defines industrial robots in VDI guideline 2860 as follows:

“Industrial robots are universal handling systems with several axes whose motions with respect to movement sequence and paths or angles are freely programmable (i.e. with no mechanical or human intervention) or sensor-guided. They can be equipped with grippers, tools or other means of production and can perform handling and/or production tasks.”

The 3D vacuum gripper robot is therefore an industrial robot that can be used for handling tasks. A workpiece can be picked up with the help of the vacuum gripper robot and moved within a workspace. This workspace is the result of the kinematic arrangement of the robot, and it defines the area that can be reached by the robot's effector. In the case of the vacuum gripper robot, the suction cup of the effector and the workspace correspond to a hollow cylinder whose vertical axis coincides with the robot's axis of rotation.

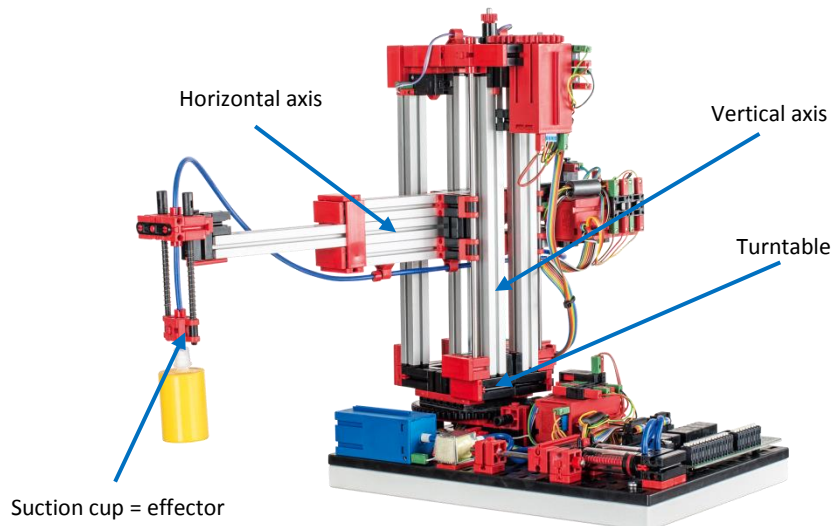

Fig. 4: kinematic arrangement of the 3D vacuum gripper

The geometry of the workspace is the result of the kinematic setup shown in Fig. 4 and comprises one rotary axis and two linear axes.

The typical job for this type of robot can be broken down into the following work steps:

- Positioning the vacuum gripper at the workpiece location
- Picking up the workpiece
- Transporting the workpiece within the workspace
- Setting down the workpiece

Positioning the vacuum gripper or transporting the workpiece can be defined as a point-to-point motion or as a continuous path. Activating the individual axes occurs sequentially and/or in parallel and is influenced significantly by obstacles or predefined intermediate stations in the workspace. A 3/2 way solenoid valve and two connected pneumatic cylinders help control the vacuum gripper.

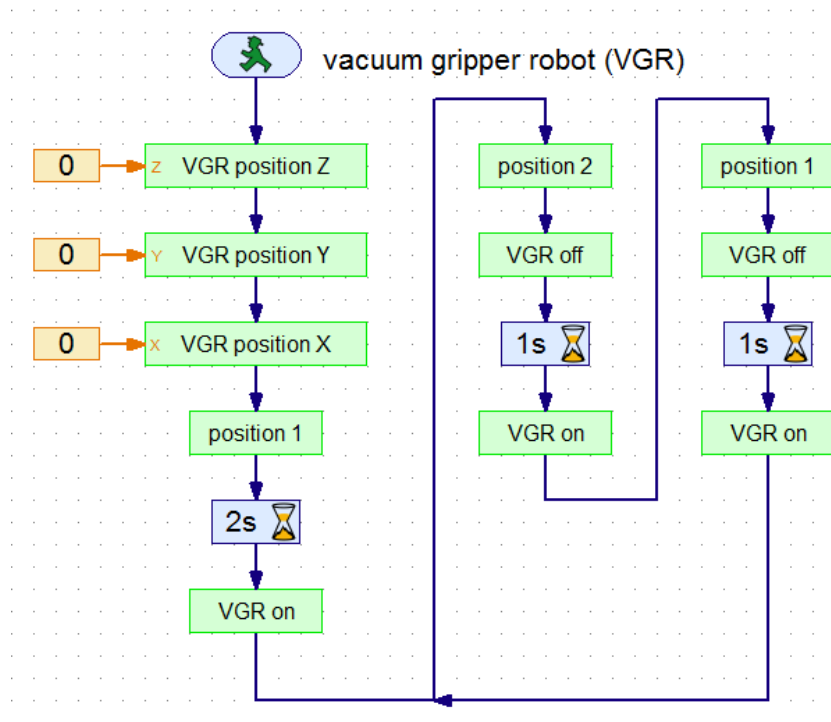

Fig. 5: 3D vacuum gripper robot program example

Figure 5 shows the pre-installed program example process. The program can be divided into four sections. First the vacuum gripper robot performs a reference run. To do this, the three axes of the robot are moved to their reference positions and then their positions or angles are set to zero. The vacuum gripper robot then initially moves to the workpiece position and picks up the workpiece. The two second time delay between positioning and then picking up the workpiece is used to adjust the workpiece. The subsequent steps are now alternately carried out in an endless loop.

- The gripper robot moves to the alternate position.
- The workpiece is set down.
- The gripper robot pauses a second at this position.
- It then picks up the workpiece again.

Positioning is then via point-to-point motion, where the axes are actuated in parallel. The positioning algorithm takes into account the rotation direction of the motor when counting the encoder pulse, where the correct position or correct angle of the axes can be determined for monotonic movement. Since point-to-point movements are always monotonic, this algorithm can be used in this case. For this purpose the following measurement and set point values are required:

- Target position or target angle
- Actual position or actual angle
- State of reference switch
- Motor direction of rotation
- Measured encoder pulse

The implementation of the vacuum process includes on the one hand the lowering of the vacuum in order to establish an air-tight connection between the workpiece and the suction cup and on the other the production of a vacuum so that the workpiece will temporarily stick to the suction cup. The

suction cup is then lifted again with the workpiece. The function for setting down the workpiece can also be divided into three sections. First the suction cup is lowered, then the air is removed from the cylinder, eliminating the vacuum, and finally the suction cup is raised again.



## Industrial robots – definition and characteristics

Name five key words that describe an industrial robot according to VDI guideline 2860.

---

---

---

---

---

What tasks can the vacuum gripper robot be used for?

---

---

---

What is considered a robot workspace and how is this space defined?

---

---

---

What is the shape of the vacuum gripper robot workspace?

---

---

---

What is the kinematic arrangement of the vacuum gripper robot?

---

---

---

## Industrial robots – definition and characteristics

**ANSWER**

Name five key words that describe an industrial robot according to VDI guideline 2860.

- *Universal handling systems with several axes*
- *Freely programmable with respect to movement sequence and paths or angles*
- *Possibly sensor-guided*
- *Can be equipped with grippers, tools or other means of production*
- *Can perform handling and/or production tasks*

What tasks can the vacuum gripper robot be used for?

*The vacuum gripper robot can be used for handling tasks.*

What is considered a robot workspace and how is this space defined?

*The workspace of an industrial robot is the area that can be reached by the robot's effector. The workspace is defined by the kinematic arrangement of the robot, which is determined by the type and arrangement of the movable axes.*

What is the shape of the vacuum gripper robot workspace?

*The workspace of the vacuum gripper robot can be described as a hollow cylinder.*

What is the kinematic arrangement of the vacuum gripper robot?

*The kinematic arrangement of the vacuum gripper robot consists of a turntable and two linear axes.*

# Kinematic arrangement of the vacuum gripper robot

Identify and name the movable axes and effector of the vacuum gripper robot.

---

---

---

---

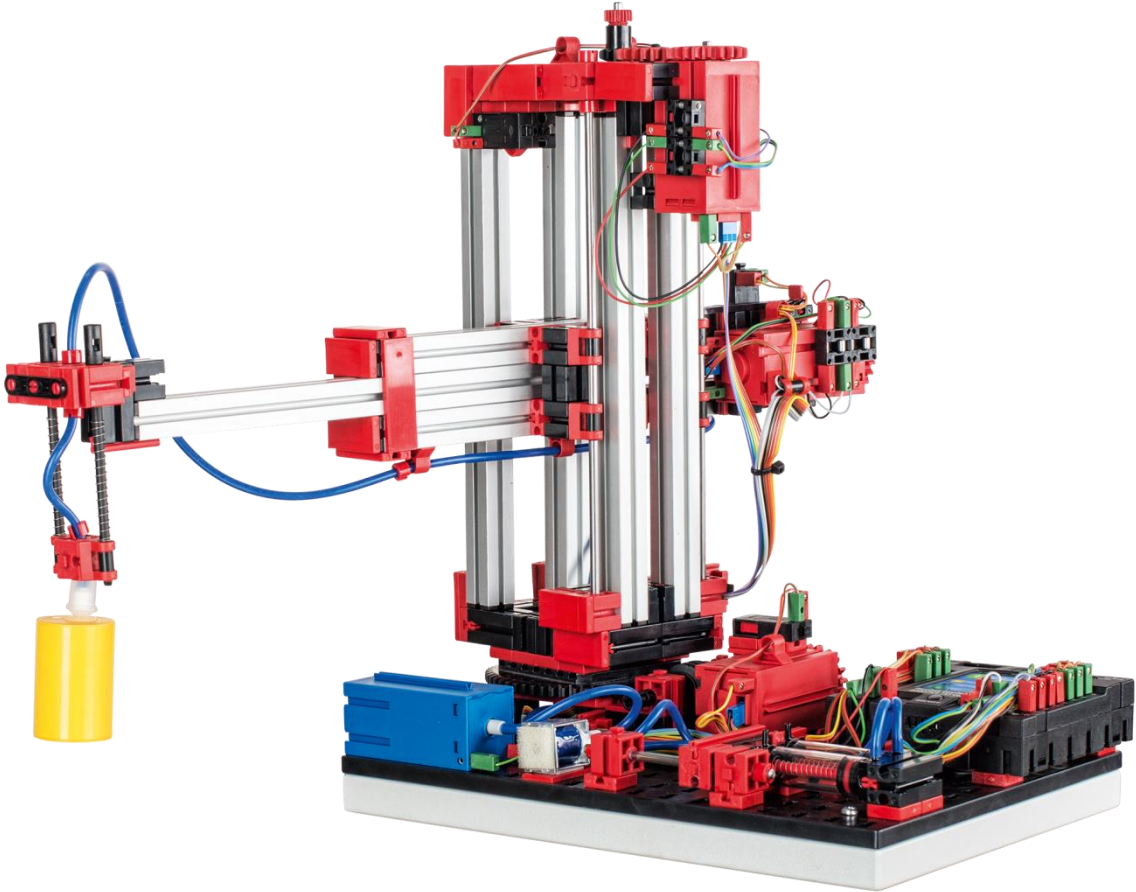

# Kinematic arrangement of the vacuum gripper robot

**ANSWER**

Identify and name the movable axes and effector of the vacuum gripper robot.

- 1 Turntable
- 2 Horizontal axis
- 3 Vertical axis
- 4 Suction cup

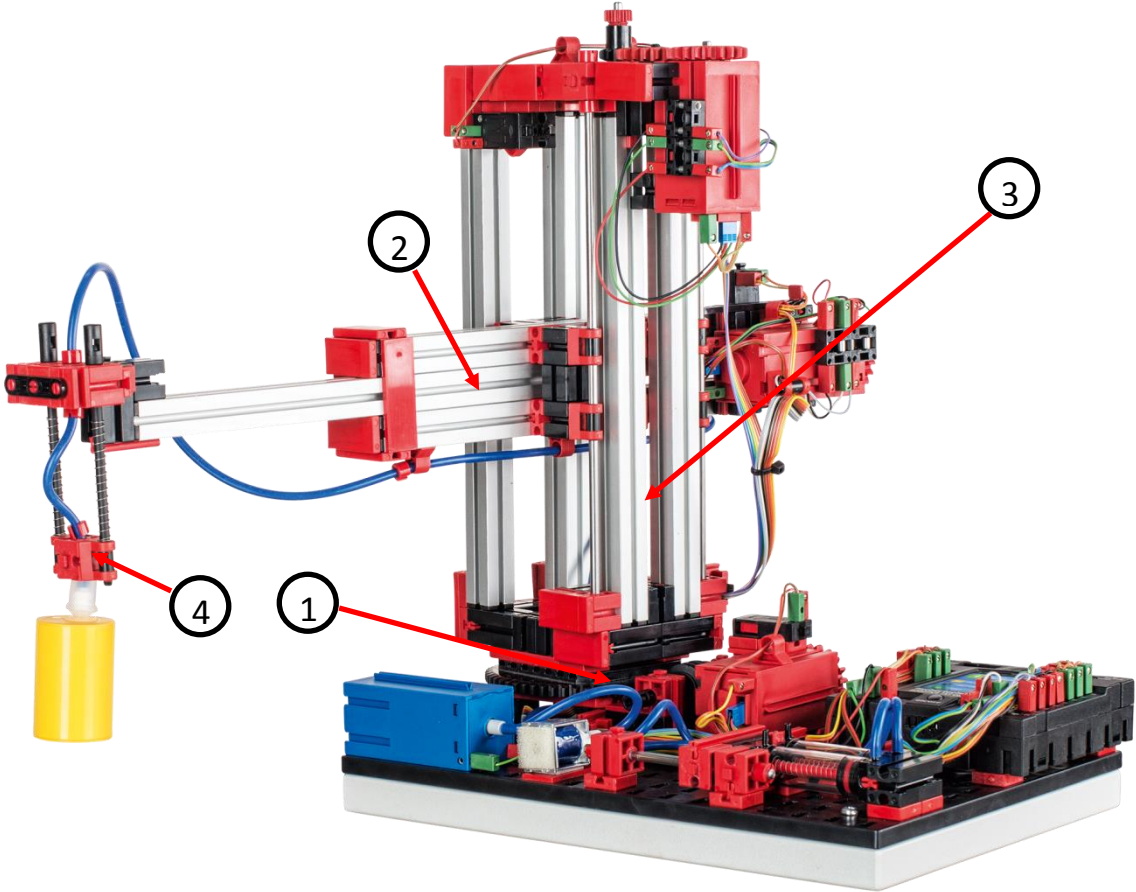

## Handling tasks

Name the four typical jobs of the vacuum gripper robot.

---

---

---

---

For which two job types can positioning jobs be defined?

---

---

What controls the individual axes of the robot? What significantly influences actuation?

---

---

---

---

Why are reference runs necessary? Which measuring method requires reference runs?

---

---

---

---

## Handling tasks

**ANSWER**

Name the four typical jobs of the vacuum gripper robot.

- *Positioning the vacuum gripper at the workpiece location*
- *Picking up the workpiece*
- *Transporting the workpiece within the workspace*
- *Setting down the workpiece*

For which two job types can positioning jobs be defined?

- *Point-to-point motions*
- *Continuous path*

What controls the individual axes of the robot? What significantly influences actuation?

*The axes of the vacuum gripper robot can be actuated sequentially and/or in parallel.*

*Actuation is significantly affected by obstacles in the workspace and by predefined intermediate stations.*

Why are reference runs necessary? Which measuring method requires reference runs?

*Reference runs help to define the absolute position or absolute angle.*

*They are used for incremental measuring.*

# Programming the vacuum gripper robot

Highlight and label the four areas of the program example.

---

---

---

---

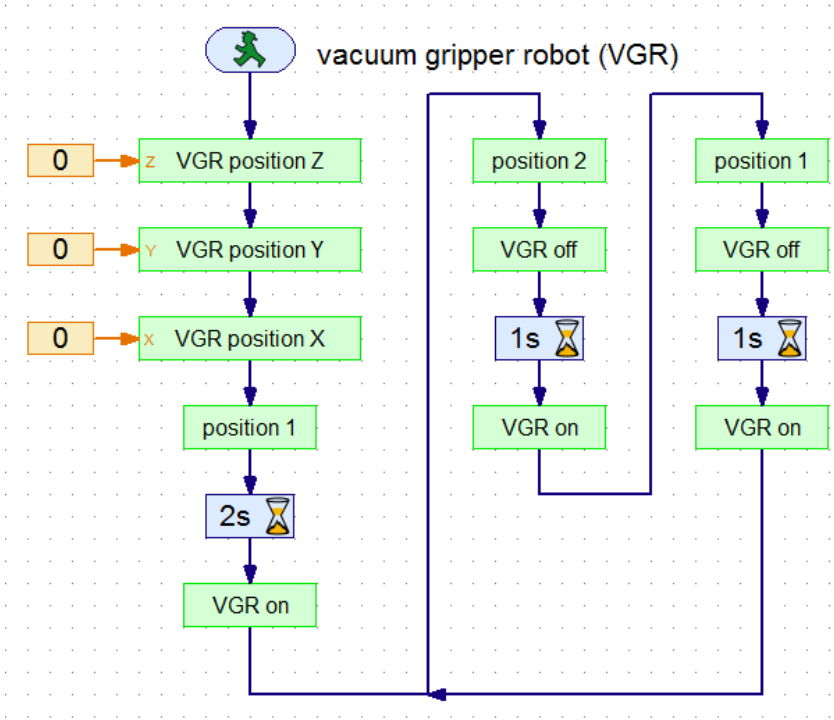

What five pieces of information are required to obtain the correct position or angle from the encoder signal?

---

---

---

---

---

## Programming the vacuum gripper robot

**ANSWER**

Highlight and label the four areas of the program example.

1 Reference run

2 Initial positioning and pickup of workpiece

3 Workpiece transport, deposit and pick up again – variant 2

4 Workpiece transport, deposit and pick up again – variant 1

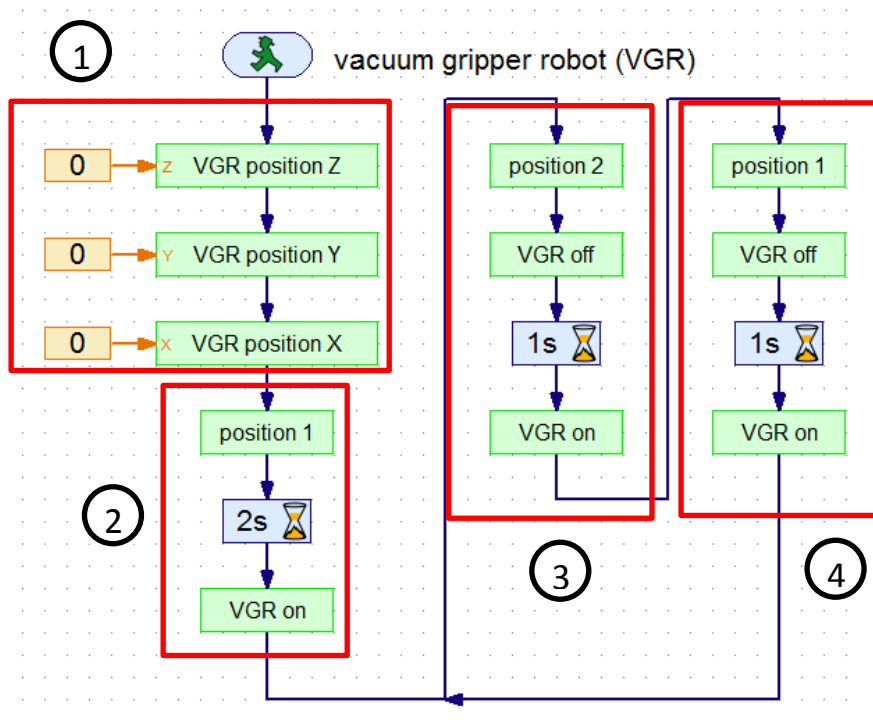

What five pieces of information are required to obtain the correct position or angle from the encoder signal?

*Target position or target angle*

*Actual position or actual angle*

*State of reference switch*

*Motor direction of rotation*

*Measured encoder pulse*



## Maintenance and troubleshooting

The vacuum gripper robot is generally maintenance free. It may be necessary to re-grease the worm or worm screw nut. Keep in mind that it is possible to avoid a friction-type connection by applying a thin layer of grease at specific locations.

**Problem:** One of the three motors/axes is no longer moving.

**Solution:** Visually inspect the robot. Specifically check the cabling of the failed motor. If necessary, use a multimeter to check if there is a broken cable.

**Problem:** One of the three motors/axes moves beyond the specified position and no longer stops on its own.

**Solution:** Verify that the three encoder cable wires are correctly connected to the TXT controller. The “Interface Test” window may be helpful.

**Problem:** One of the three motors/axes no longer moves to the positions correctly and pauses briefly in front of the desired position.

**Solution:** Verify that the robot chucks and chuck nuts are secured tightly. If not, it is possible that there could be slippage between the friction lock parts.

**Problem:** The suction cup loses the workpiece during transport.

**Solution:** Visually inspect the hose system. Make sure that the two connected pneumatic cylinders can extend freely and, if necessary, moisten the suction cup. Make sure that the workpieces are not dirty in order to ensure an air-tight connection between the suction cup and workpiece.