

536629
Factory Simulation 9V

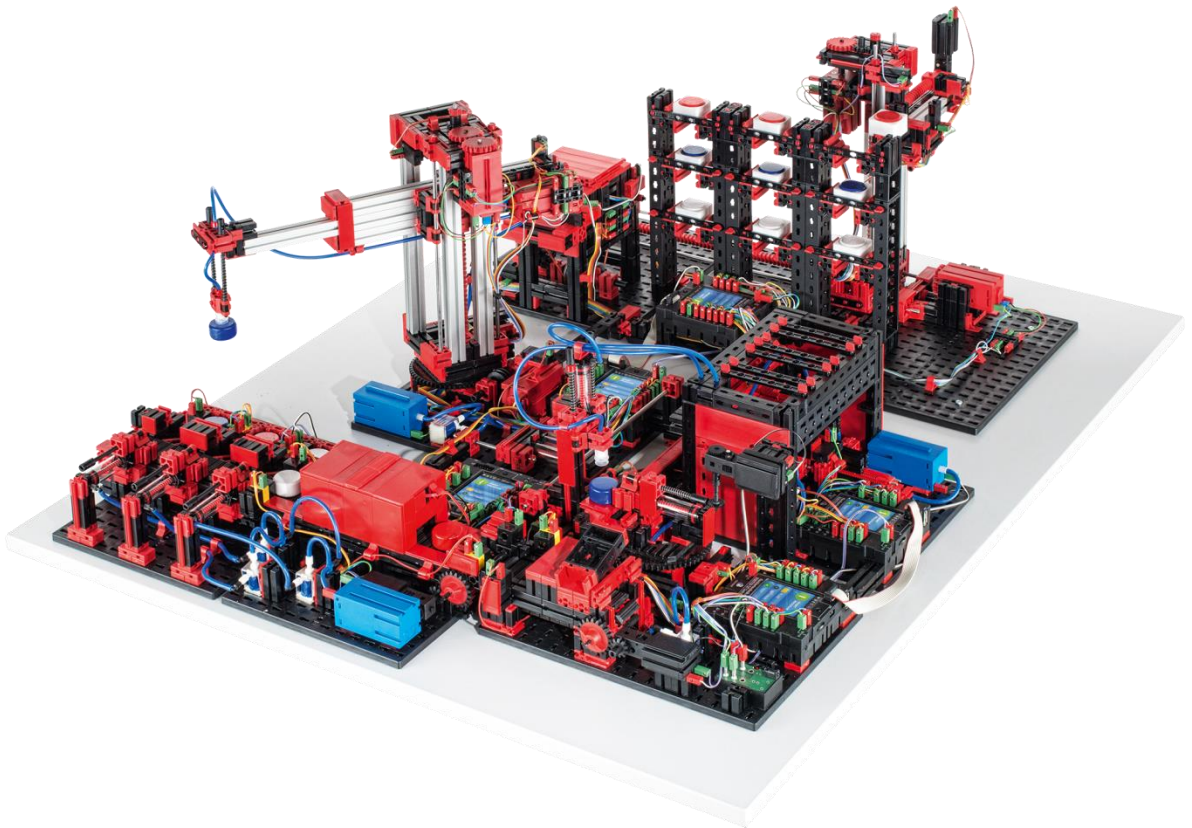

Contents

Introduction..... 2

First Steps 3

Circuit layout for the Factory Simulation 9V 4

 Controller Sorting Line with Detection..... 4

 Controller “Automated High-Bay Warehouse (HRL) + Vacuum Gripper Robot (VSG)” 4

 Controller Multi Processing Station with Oven 5

Component description..... 6

Models..... 10

 Vacuum Gripper Robot (VSG)..... 10

 Automated High-Bay Warehouse (HRL) 22

 Multi processing station with oven 31

 Sorting line with detection 36

Introduction

Factory simulation from fischertechnik is a training model, consisting of fischertechnik modules, which simulate a small factory. This consists of several individual models, such as the "automated high-bay warehouse", a "multi processing station with oven", a "vacuum gripper robot" and a "sorting line with detection". By linking several stations the processes can illustrate a processing line.

The model is controlled via five fischertechnik TXT controllers. The corresponding programs are preinstalled on these controllers and can be started from there. The "automated high-bay warehouse with vacuum gripper robot" and the "multi processing station with oven" are controlled by two TXT controllers each, which operate in an integrated master-extension setup. The second controller serves as the extension, where the master controller can control a total of 16 universal inputs, eight fast counter inputs and eight motor outputs. In this way the program is only stored on the Master controller.

The vacuum gripper robot loads the rack feeder with workpieces. This stores the workpieces in the high-bay warehouse, sorted according to color. Finally, the workpieces are taken out of storage again, brought to the multi processing station and machined there. After this the machined workpieces are sorted in the sorting line according to color and conveyed into storage locations. From there the workpieces are transported by the vacuum gripper robot back to the high-bay warehouse. This is an infinite, repeating cycle.

First Steps

After you have unpacked the "Factory Simulation" and removed the transport locks, perform a visual inspection to see whether components have come loose or been damaged during transport. If necessary, put loose components back in the correct place. Compare your model with the comparison pictures of the "Factory simulation", which is stored on the eLearning portal. Check whether all cables and hoses are connected. Using the assignment plan, the unconnected cable can be connected correctly.

Now insert the workpiece carrier in the high-bay warehouse, making sure that the recesses are pointed forwards (cf. Figure 1). Place the workpieces in the provided storage locations at the sorting line (cf. Figure 2).

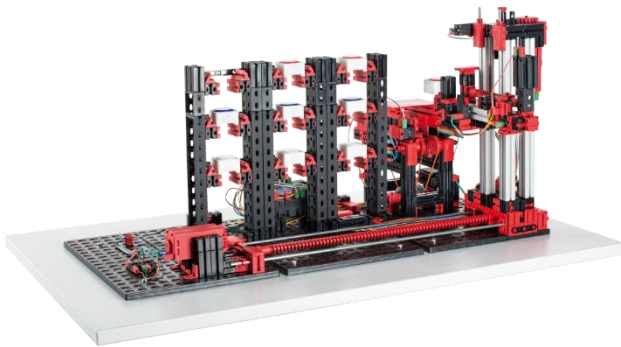

Figure 1: Workpiece carrier in high-bay warehouse

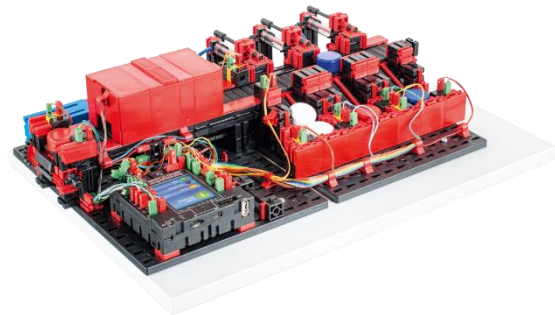

Figure 2: Workpieces in the storage locations

Now connect the TXT controller, using the power supplies, to the current and press the ON/OFF button until an image appears on the display. The preprogrammed program is already installed on the respective controller and is started automatically after switching on the controller.

Notice whether the process functions. If necessary a fine adjustment must be made. To do this open the corresponding program in the ROBOPro software and adapt the values under the tab "Calibration". Make sure to save the revised program on the TXT controller, in order to be able to start it from the controller.

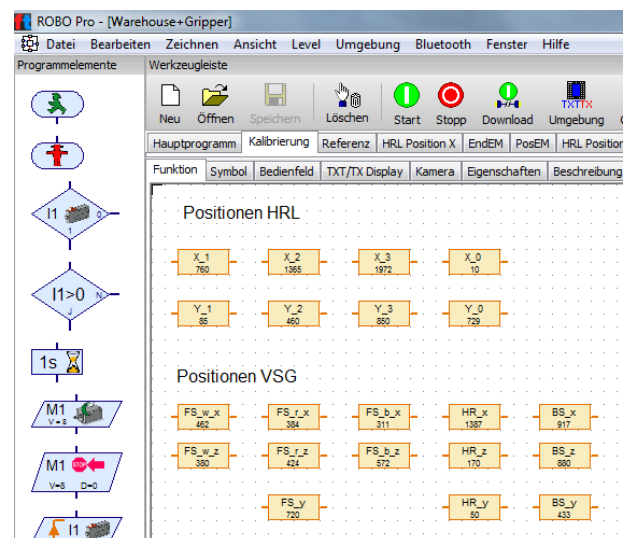

Figure 3: Calibration for HRL and VSG

Circuit layout for the Factory Simulation 9V

Controller Sorting Line with Detection

Number	Function	Input/Output
1	phototransistor color sensor	I1
2	color sensor	I2
3	phototransistor ejector	I3
4	phototransistor white	I6
5	phototransistor red	I7
6	phototransistor blue	I8
7	phototransistor white (VSG)	I6
8	phototransistor red (VSG)	I7
9	phototransistor blue (VSG)	I8
10	pulse counter	C1
11	motor conveyor belt	M1
12	valve ejector white	O5
13	valve ejector red	O6
14	valve ejector blue	O7
15	Compressor	O8

Controller “Automated High-Bay Warehouse (HRL) + Vacuum Gripper Robot (VSG)”

Number	Function	Input/Output
1	phototransistor outside	I1 (master)
2	trail sensor (signal 1)	I2 (master)
3	trail sensor (signal 2)	I3 (master)
4	phototransistor inside	I4 (master)
5	reference switch horizontal axis (HRL)	I5 (master)
6	reference switch cantilever retract (HRL)	I6 (master)
7	reference switch cantilever extend (HRL)	I7 (master)
8	reference switch vertical axis (HRL)	I8 (master)
9	encoder horizontal axis (HRL)	C2 (master)
10	encoder vertical axis (HRL)	C4 (master)
11	motor conveyor belt (HRL)	M1 (master)
12	motor horizontal axis (HRL)	M2 (master)
13	motor cantilever (HRL)	M3 (master)
14	motor vertical axis (HRL)	M4 (master)
15	reference switch rotate (VSG)	I1 (slave)
16	reference switch vertical axis (VSG)	I2 (slave)
17	reference switch horizontal axis (VSG)	I3 (slave)
18	phototransistor white (sorting line)	I4 (slave)
19	phototransistor red (sorting line)	I5 (slave)
20	phototransistor blue (sorting line)	I6 (slave)
21	encoder rotate (VSG)	C1 (slave)
22	encoder vertical axis (VSG)	C2 (slave)
23	encoder horizontal axis	C3 (slave)
24	motor rotate (VSG)	M1 (slave)
25	motor vertical axis (VSG)	M2 (slave)
26	motor horizontal axis	M3 (slave)
27	compressor	O7 (slave)
28	valve	O8 (slave)

Controller Multi Processing Station with Oven

Number	Function	Input/Output
1	reference switch turn-table (position vacuum)	I1 (master)
2	reference switch turn-table (position saw)	I2 (master)
3	reference switch turn-table (position belt)	I3 (master)
4	phototransistor end of conveyor belt	I4 (master)
5	reference switch vacuum (position turn-table)	I5 (master)
6	motor turn-table	M1 (master)
7	motor saw	M2 (master)
8	motor conveyor belt	M3 (master)
9	valve ejection	O7 (master)
10	compressor	O8 (master)
11	reference switch oven feeder retract	I1 (slave)
12	reference switch oven feeder inside extend	I2 (slave)
13	reference switch vacuum (position oven)	I3 (slave)
14	phototransistor	I5 (slave)
15	motor oven feeder	M1 (slave)
16	motor vacuum	M2 (slave)
17	valve vacuum	O5 (slave)
18	valve lowering	O6 (slave)
19	valve oven door	O7 (slave)
20	light oven	O8 (slave)

Component description

Encoder motor:

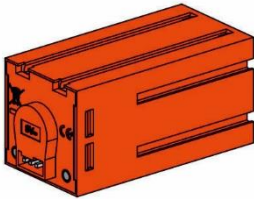

The vacuum gripper robot and the vertical and horizontal axes of the automated high-bay warehouse are driven with so-called encoder motors. This is possible through permanent magnet DC motors, which enable the incremental measurement of angles with the help of Hall effect sensors. The encoder motors operate at a rated voltage of 9V DC and have a maximum output of 1.2 W at 105 rpm. The current input at maximum power is 386 mA. The integrated gearbox gear ratio is 21.1:1. This means that the encoder produces three pulses per motor shaft rotation or 63.3 pulses per rotation of the gearbox output shaft. Since only one pulse is indexed, the encoder used cannot distinguish the direction in which the motor is rotating.

The encoder is connected to the TXT controller via a triple core cable with a red wire for the 9 V output and a green wire for the ground connection. The black cable transmits the signal (NPN open collector output, 1 kHz max.) and needs to be connected to a fast counter input (C1-C4). If a fischertechnik controller will not be used to read out the encoder signal, the use of a pull-up resistor (4.7-10kΩ) is required.

Mini-switch:

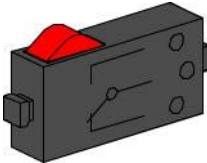

With the factory simulation the mini-switches are frequently used as reference switches. When using incremental measuring methods, a reference switch is used to determine the absolute position or absolute angle. The mini-switch used for this purpose includes a changeover switch and can be used both as a normally closed contact and as a normally open contact. When the switch is actuated, equipotential bonding occurs between contact 1 and contact 3, while the connection between contact 1 and contact 2 is separated. Figure 4 shows the schematic circuit diagram of the mini-switch.

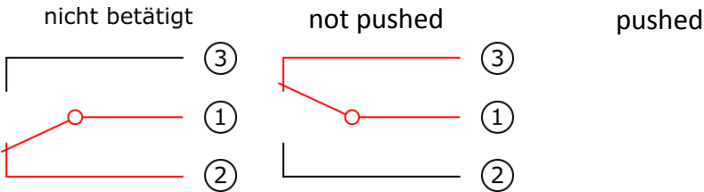
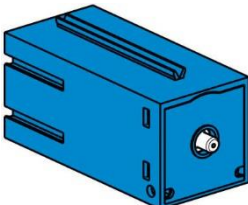

Figure 4: Mini-switch circuit diagram

Compressor:



Diaphragm pumps are used as compressed air source for the pneumatic controls. This type of diaphragm pump consists of two chambers

separated by a diaphragm (see Figure 5). A cam moves a piston in one of the two chambers up and down, causing the air in the other chamber to be drawn in or pressed out. If the piston moves to the right, the diaphragm is pulled back, causing air to be pulled into the second chamber through the inlet valve. If the piston moves to the left, the diaphragm presses the air out of the pumphead through the outlet valve. The compressor used in this case operates at a rated voltage of 9V DC and produces an overpressure of approximately 0.7 bar. The maximum current input of the compressor is 200 mA.

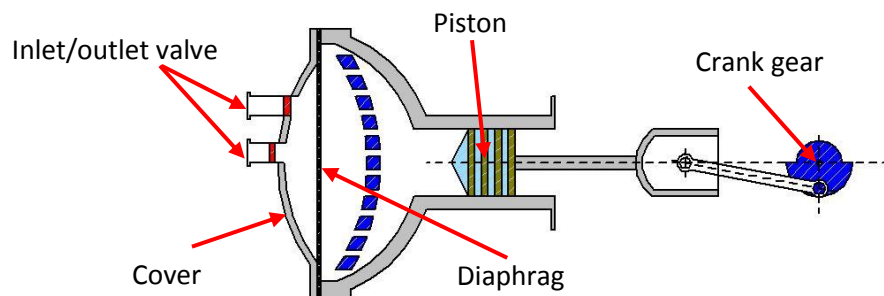
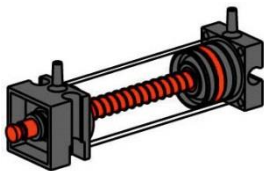

Figure 5: Schematic drawing of the diaphragm pump

Pneumatic cylinders:



Two pneumatic cylinders handle the suction function of the vacuum gripper robot and are controlled with the help of a 3/2 way solenoid valve. In the case of the pneumatic cylinders, a piston divides the volume of the cylinder into two chambers. Differing pressure between these two chambers results in force placed on the piston, causing the piston to move. This movement corresponds to a change in volume in both chambers. Two cylinders are then mechanically connected in order to create a vacuum, which is pressure that is lower than the ambient pressure. If a cylinder is then supplied with excess pressure, the two piston rods extend, causing the volume to increase in the chamber closed by the suction cup. This increase in volume is accompanied by a drop in pressure in this chamber.

S motor:

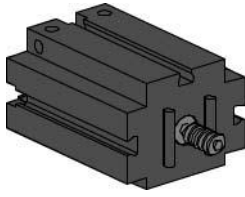

Mechanical components, for example the conveyor belts, can be driven using the S-motor. This compact motor is a permanent magnet DC motor that can be used together with an attachable motor reducing gearbox. The motor is operated at a rated voltage of 9V DC and the maximum current input is 650 mA. The result is a maximum torque of 4.8 mNm and an idling speed of 9,500 rpm. The motor reducing gearbox has a gear ratio of 64.8:1 and a lateral output.

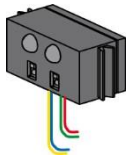

IR trail sensor:

The IR trail sensor is a digital infrared sensor, which can detect a black trail on a white background at a distance of 5 – 30 mm. It consists of two transmission and two receiver elements. Two universal inputs and the 9V voltage output are required for the connection.

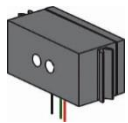

color sensor

color sensors are mostly used in automation technology, for instance. During this process, for example, the color or a color imprint is to be examined to ensure that the correct components are installed. The fischertechnik color sensor transmits red light, which is reflected with a different intensity from different colored surfaces. The intensity of the reflected light is measured by the phototransistor and output as a voltage value between 0 V and 9 V. The measured value is dependent on the ambient brightness and the distance of the sensor from the colored surface. The connection is made using three cables. The red cable is connected to the TXT controller 9V DC output, the green cable is connected to ground and the black cable is connected to a universal input. In ROBOPRO this measured value is output as a numerical value between 0 and 9,000.



Phototransistor:

Phototransistors are used as light barriers in the factory simulation. A phototransistor conducts electricity from a certain level of brightness. However, if this luminescence threshold is exceeded, the phototransistor loses its conductivity. Together with a lens tip lamp, which faces the phototransistor, the phototransistor can be used as a light barrier. If the cone of light from an object is interrupted, the light barrier no longer conducts electricity. A stray light hood can be used to reduce the effects of ambient light.

Caution: When connecting the phototransistor to the power supply, pay particular attention to correct polarity. Connect the positive pole at the red marking on the phototransistor.

3/2 way solenoid valve:

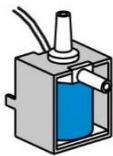

3/2 way solenoid valves are used to control the pneumatic cylinders. These control valves have three connection points and two control states. The switching operations are carried out by a solenoid coil (a), which operates against a spring (c). When voltage is applied to the solenoid, the movable core (b) of the coil moves against the spring as a result of Lorentz force, causing the valve to open. Open in this case means that the compressed air connection (current description: 1, previous description: P) is connected with the cylinder connection (2, previously A). If this voltage drops, the spring pushes the core back again, and the valve closes again. In this position, the cylinder connection (2, previously A) is connected with the air vent (3, previously R). Figure 6 shows a schematic drawing of the 3/2 way solenoid valve.

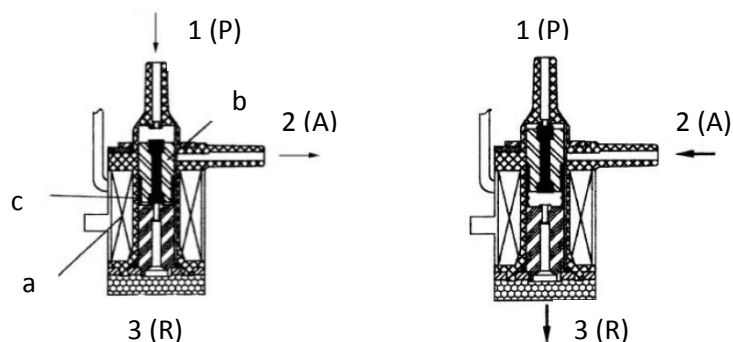

Figure 6: 3/2 way solenoid valve

Models

Vacuum Gripper Robot (VSG)

What are robots?

The Society of German Engineers (VDI) defines industrial robots in VDI guideline 2860 as follows:

“Industrial robots are universal handling systems with several axes whose motions with respect to movement sequence and paths or angles are freely programmable (i.e. with no mechanical or human intervention) or sensor-guided. They can be equipped with grippers, tools or other means of production and can perform handling and/or production tasks.”

The 3D vacuum gripper robot is therefore an industrial robot that can be used for handling tasks. A workpiece can be picked up with the help of the vacuum gripper robot and moved within a workspace. This workspace is the result of the kinematic arrangement of the robot, and it defines the area that can be reached by the robot's effector. In the case of the vacuum gripper robot, the suction cup of the effector and the workspace correspond to a hollow cylinder whose vertical axis coincides with the robot's axis of rotation.

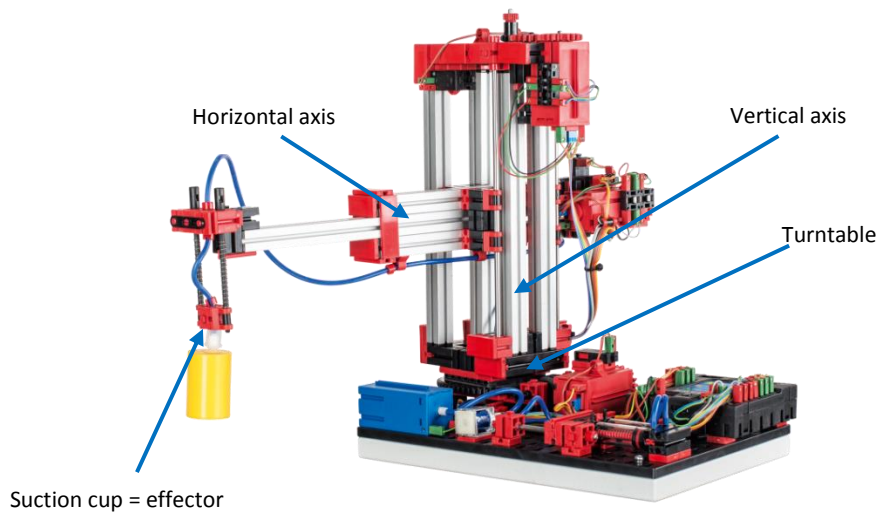

Figure 7: kinematic arrangement of the 3D vacuum gripper robot

The geometry of the workspace is the result of the kinematic setup shown in Figure 7 and comprises one rotary axis and two linear axes.

The typical job for this type of robot can be broken down into the following work steps:

- Positioning the vacuum gripper at the workpiece location
- Picking up the workpiece
- Transporting the workpiece within the workspace
- Setting down the workpiece

Positioning the vacuum gripper or transporting the workpiece can be defined as a point-to-point motion or as a continuous path. Activating the individual axes occurs sequentially and/or in parallel and is influenced significantly by obstacles or predefined intermediate stations in the workspace. A 3/2 way solenoid valve and two connected pneumatic cylinders help control the vacuum gripper.

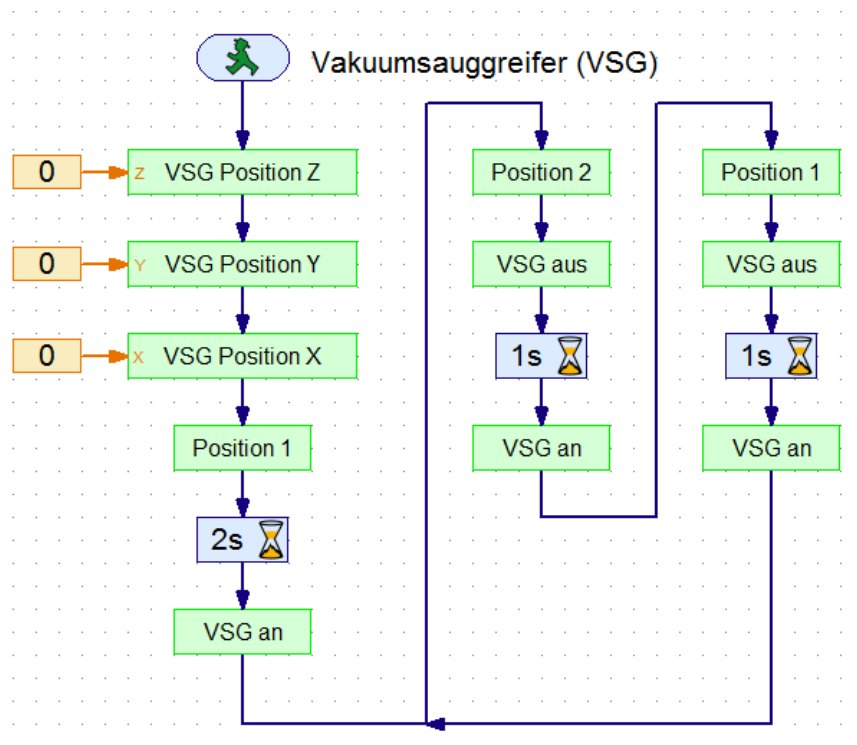

Figure 8: 3D vacuum gripper robot program example

Figure 5 shows the pre-installed program example process of the vacuum gripper robot. The program can be divided into four sections. First the vacuum gripper robot performs a reference run. To do this, the three axes of the robot are moved to their reference positions and then their positions or angles are set to zero. The vacuum gripper robot then initially moves to the workpiece position and picks up the workpiece. The two second time delay between positioning and then picking up the workpiece is used to adjust the workpiece. The subsequent steps are now alternately carried out in an endless loop.

- The gripper robot moves to the alternate position.
- The workpiece is set down.
- The gripper robot pauses a second at this position.
- It then picks up the workpiece again.

Positioning is then via point-to-point motion, where the axes are actuated in parallel.

The positioning algorithm takes into account the rotation direction of the motor when counting the encoder pulse, where the correct position or correct angle of the axes can be determined for

monotonic movement. Since point-to-point movements are always monotonic, this algorithm can be used in this case. For this purpose the following measurement and set point values are required:

- Target position or target angle
- Actual position or actual angle
- State of reference switch
- Motor direction of rotation
- Measured encoder pulse

The implementation of the vacuum process includes on the one hand the lowering of the vacuum in order to establish an air-tight connection between the workpiece and the suction cup and on the other the production of a vacuum so that the workpiece will temporarily stick to the suction cup. The suction cup is then lifted again with the workpiece. The function for setting down the workpiece can also be divided into three sections. First the suction cup is lowered, then the air is removed from the cylinder, eliminating the vacuum, and finally the suction cup is raised again.

In the factory simulation the vacuum gripper robot acts together with the automated high-bay warehouse. This saves the joined together, coordinated program on the TXT controller on the high-bay warehouse and the TXT controller on the vacuum gripper robot is only used as an expansion of the inputs and outputs. In this way the individual components can be linked with each other and a factory simulation can be done. During this the vacuum gripper robot loads the rack feeder with workpieces. If all 9 workpieces (3 white, 3 red, 3 blue) are stored in the high-bay warehouse, these are brought sequentially from the vacuum gripper robot to the multi processing station with oven and processed there. After the workpieces in the sorting line have been sorted according to color, the vacuum gripper robot transports these back to the high-bay warehouse.

Industrial robots – definition and characteristics

Name five key words that describe an industrial robot according to VDI guideline 2860.

What tasks can the vacuum gripper robot be used for?

What is considered a robot workspace and how is this space defined?

What is the shape of the vacuum gripper robot workspace?

What is the kinematic arrangement of the vacuum gripper robot?

Industrial robots – definition and characteristics

ANSWER

Name five key words that describe an industrial robot according to VDI guideline 2860.

- *Universal handling systems with several axes*
- *Freely programmable with respect to movement sequence and paths or angles*
- *Possibly sensor-guided*
- *Can be equipped with grippers, tools or other means of production*
- *Can perform handling and/or production tasks*

What tasks can the vacuum gripper robot be used for?

The vacuum gripper robot can be used for handling tasks.

What is considered a robot workspace and how is this space defined?

The workspace of an industrial robot is the area that can be reached by the robot's effector. The workspace is defined by the kinematic arrangement of the robot, which is determined by the type and arrangement of the movable axes.

What is the shape of the vacuum gripper robot workspace?

The workspace of the vacuum gripper robot is the area that can be reached by the effector of the robot.

What is the kinematic arrangement of the vacuum gripper robot?

The kinematic arrangement of the vacuum gripper robot consists of a turntable and two linear axes.

Kinematic arrangement of the vacuum gripper robot

Identify and name the movable axes and effector of the vacuum gripper robot.

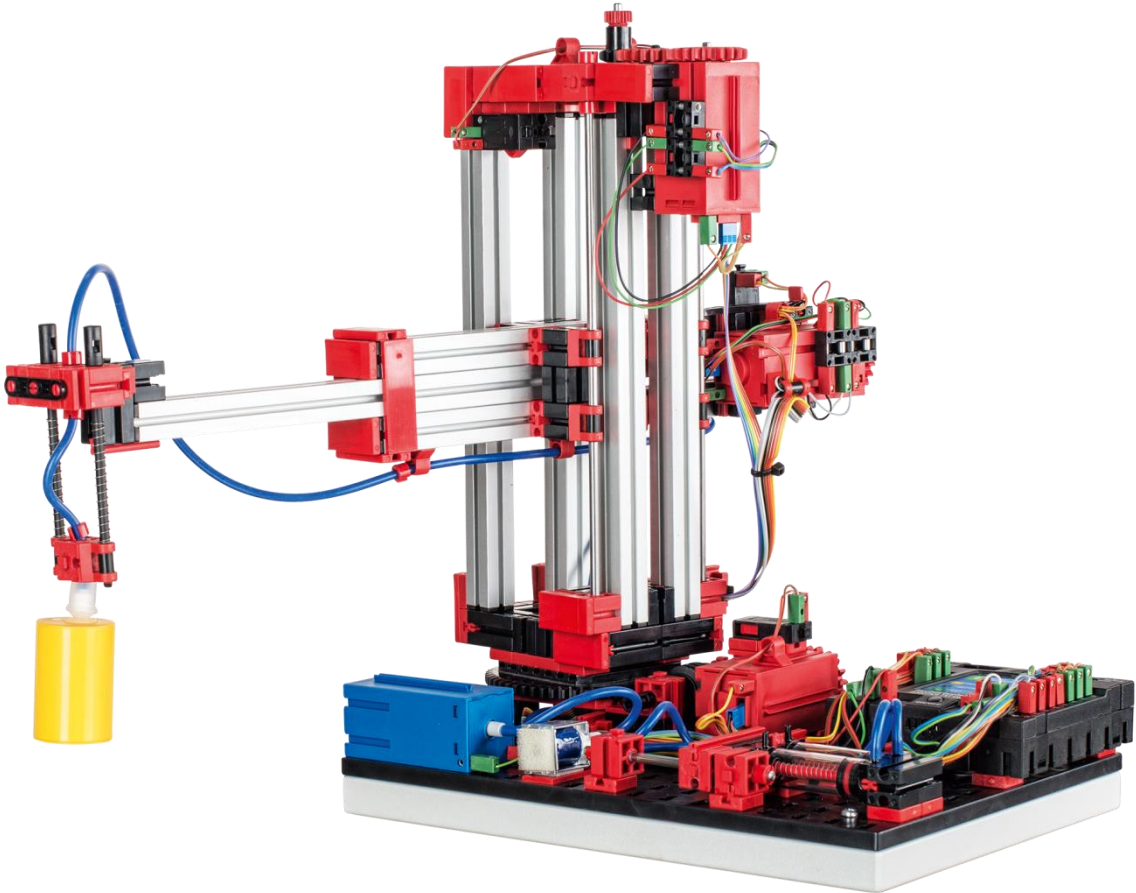

Kinematic arrangement of the vacuum gripper robot

ANSWER

Identify and name the movable axes and effector of the vacuum gripper robot.

- 1 Turntable
- 2 Horizontal axis
- 3 Vertical axis
- 4 Suction cup

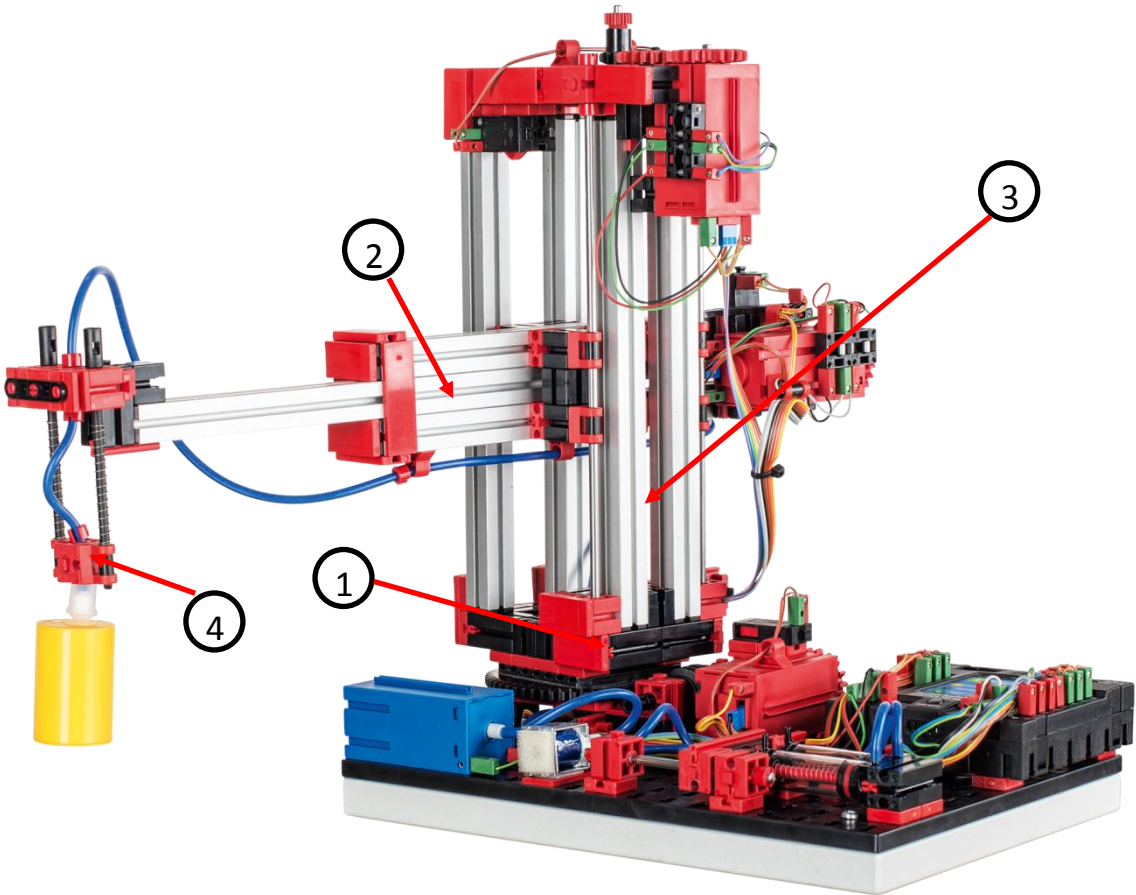

Handling tasks

Name the four typical jobs of the vacuum gripper robot.

For which two job types can positioning jobs be defined?

What controls the individual axes of the robot? What significantly influences actuation?

Why are reference runs necessary? Which measuring method requires reference runs?

Handling tasks

ANSWER

Name the four typical jobs of the vacuum gripper robot.

- *Positioning the vacuum gripper at the workpiece location*
- *Picking up the workpiece*
- *Transporting the workpiece within the workspace*
- *Setting down the workpiece*

For which two job types can positioning jobs be defined?

- *Point-to-point motions*
- *Continuous path*

What controls the individual axes of the robot? What significantly influences actuation?

The axes of the vacuum gripper robot can be actuated sequentially and/or in parallel.

Actuation is significantly affected by obstacles in the workspace and by predefined intermediate stations.

Why are reference runs necessary? Which measuring method requires reference runs?

Reference runs help to define the absolute position or absolute angle.

They are used for incremental measuring.

Programming the vacuum gripper robot

Highlight and label the four areas of the program example.

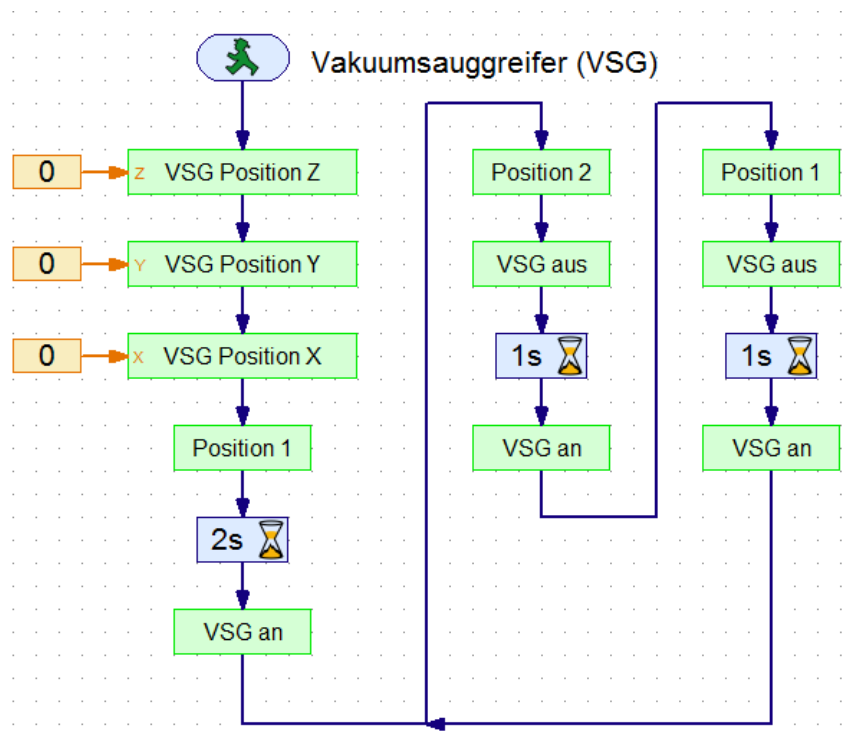

What five pieces of information are required to obtain the correct position or angle from the encoder signal?

Programming the vacuum gripper robot

ANSWER

Highlight and label the four areas of the program example.

1 Reference run

2 Initial positioning and pickup of workpiece

3 Workpiece transport, deposit and pick up again – variant 2

4 Workpiece transport, deposit and pick up again – variant 1

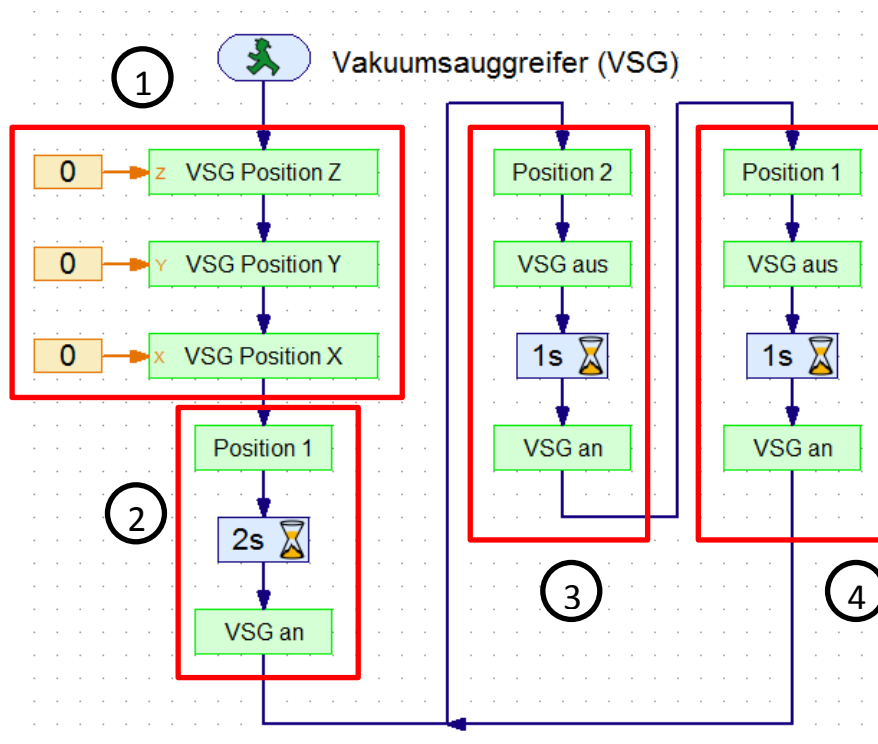

What five pieces of information are required to obtain the correct position or angle from the encoder signal?

Target position or target angle

Actual position or actual angle

State of reference switch

Motor direction of rotation

Measured encoder pulse

Maintenance and troubleshooting

The vacuum gripper robot is generally maintenance free. It may be necessary to re-grease the worm or worm screw nut. Keep in mind that it is possible to avoid a friction-type connection by applying a thin layer of grease at specific locations.

Problem: One of the three motors/axes is no longer moving.

Solution: Visually inspect the robot. Specifically check the cabling of the failed motor. If necessary, use a multimeter to check if there is a broken cable.

Problem: One of the three motors/axes moves beyond the specified position and no longer stops on its own.

Solution: Verify that the three encoder cable wires are correctly connected to the TXT controller. The "Interface Test" window may be helpful.

Problem: One of the three motors/axes no longer moves to the positions correctly and pauses briefly in front of the desired position.

Solution: Verify that the robot chucks and chuck nuts are secured tightly. If not, it is possible that there could be slippage between the friction lock parts or that the worm screw nut is blocked.

Problem: The suction cup loses the workpiece during transport.

Solution: Visually inspect the hose system. Make sure that the two connected pneumatic cylinders can extend freely and, if necessary, moisten the suction cup. Make sure that the workpieces are not dirty in order to ensure an air-tight connection between the suction cup and workpiece.

Problem: The suction cup loses the workpiece when picking up / loses the shelf when setting down.

Solution: Adapt the position values in the sub-program "Calibration".

Automated High-Bay Warehouse (HRL)

What is a high-bay warehouse?

A high-bay warehouse is a space-saving storage area for storing and retrieving goods. In most cases high-bay warehouses are designed as pallet rack storage systems. This standardization provides for a high level of automation and connection to an ERP (Enterprise Resource Planning) system. High-bay warehouses are characterized by superior space utilization and high initial capital costs.

Storing and retrieving goods is handled by rack feeders that move in a lane between two rows of racks. This area is part of the receiving station, where identification of goods also takes place. Using conveyor systems, such as chain, roller or vertical conveyors, the goods arrive and are transferred to the rack feeders. If the rack feeders are automated, no one is allowed to enter this area. In the case of the automated high-bay warehouse, the goods are provided on a conveyor belt. The goods are identified by a barcode, which is ready by the trail sensor.

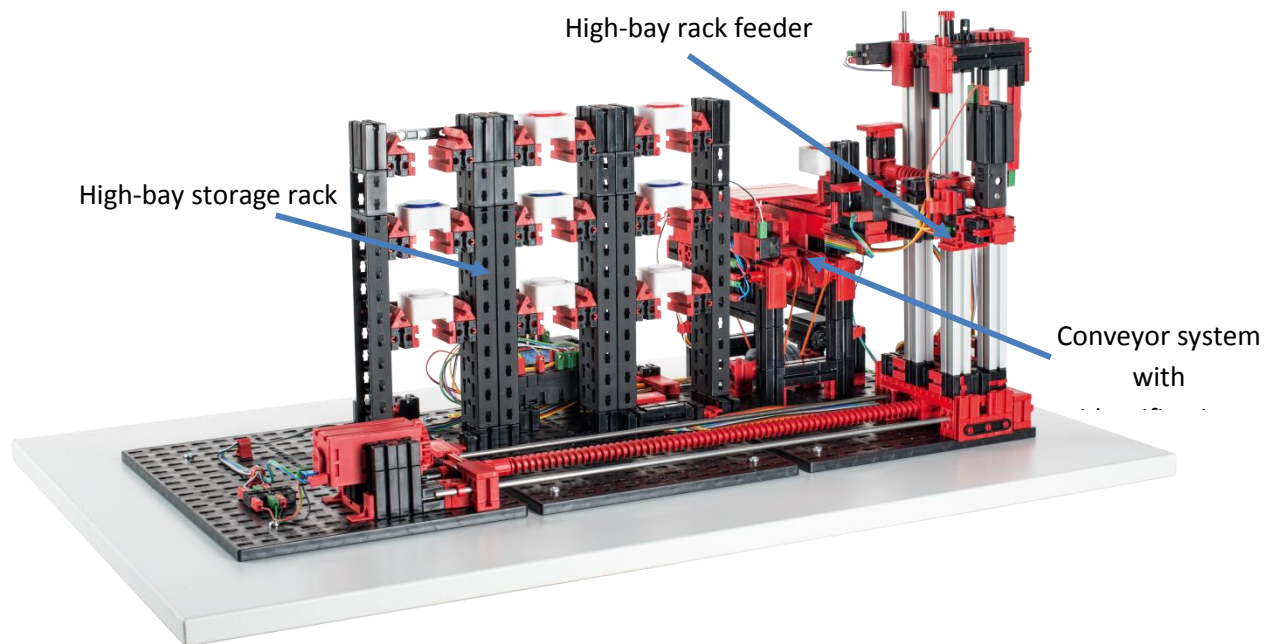

Figure 9: High-bay warehouse areas

Goods are frequently stored based on the dynamic warehousing principle. There is no fixed arrangement between storage position and goods, so the goods to be stored are placed in any free spot. This promises path efficiency. The warehouse management system saves the position of the stored goods, making them available. A (partly) automated identification of goods, which is usually done using FRID chips or barcodes at a central location called the identification site, and standardization of storage areas (same external dimensions, same permitted unit weights) are indispensable.

The ABC strategy in which the warehouse is divided into three zones at varying distances from the storage/retrieval area, is used to further streamline the pathways. Frequently required goods are

placed in the A zone, which is directly next to the storage/retrieval area. Rarely needed goods are correspondingly stored in the C zone, which is far away from the storage/retrieval area.

In the case of the automated high-bay warehouse, the static warehousing is demonstrated. In the case of static warehousing, for instance, each row is assigned a color. For instance, the top row is assigned the color white, the middle row is assigned red and the bottom row is assigned blue. The individual colored rows are filled from the position closest to the pre-loading zone to the position farthest away from the pre-loading zone. In the case of dynamic storage, there is no fixed assignment between rack row and color. This results in the high-bay rack feeder storing the workpiece in any spot available. The assignment between color and selected storage position has to be saved by the warehouse management system.

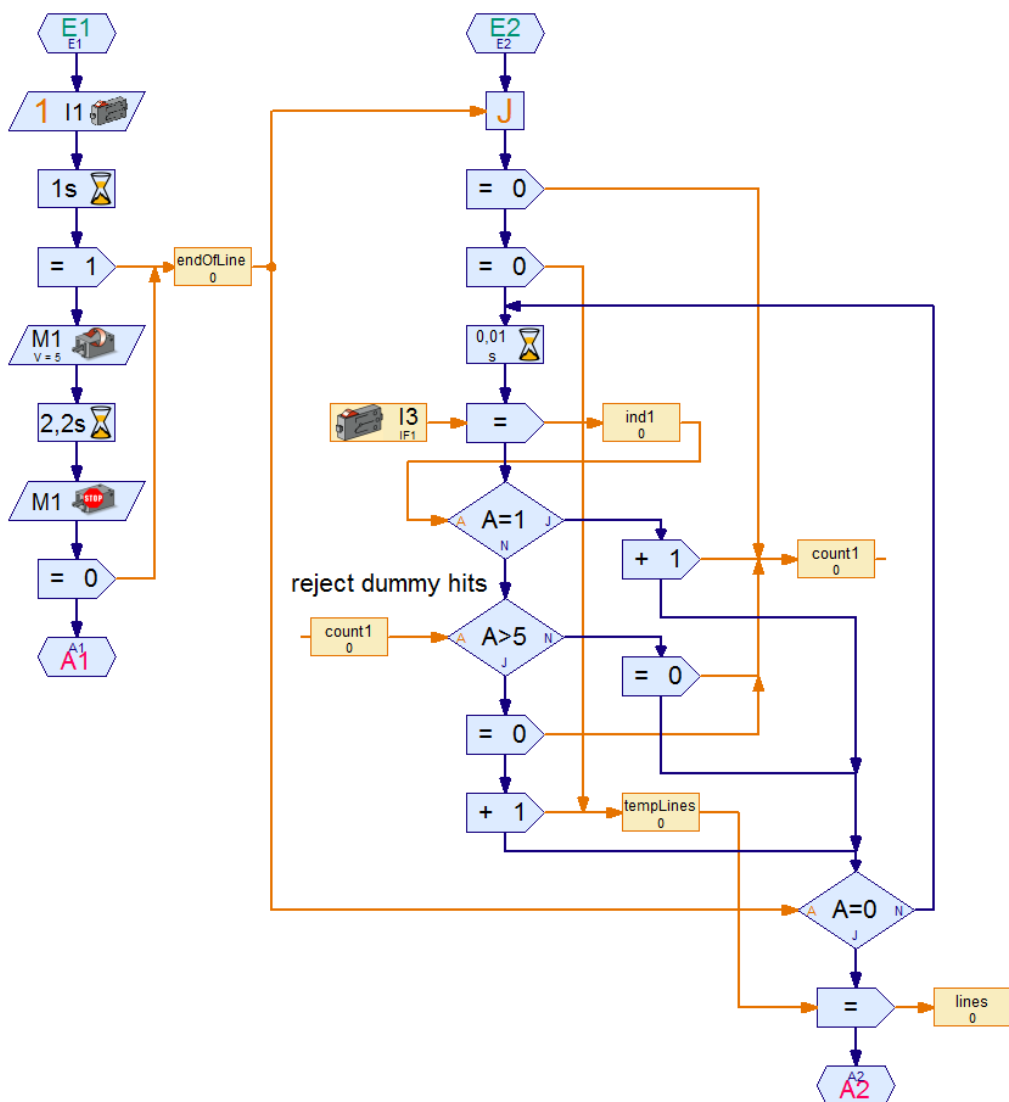

Figure 10: Algorithm for barcode recognition in ROBOPRO

The workpiece is identified by the automated high-bay warehouse using a simple barcode. The workpiece carriers have a code on them, which is assigned the color white, red or blue. This code is analyzed by a trail sensor. The trail sensor registers the differences in light and dark and interprets these either as a mark or as a reflection depending on the width. Reflections occur frequently on the edges of workpiece carriers and need to be dismissed in order to prevent false interpretations. The

difference is detected as a result of the width of the bright areas or the number of sequential time increments that are interpreted as bright. The bright areas with more than five sequential time increments are considered a mark. Figure 10 shows how this algorithm is implemented for barcode detection in ROBOPro. This thus defined minimum width limits the number of patterns to be distinguished which can be used to identify the workpiece, but it is sufficient for coding the three colors.

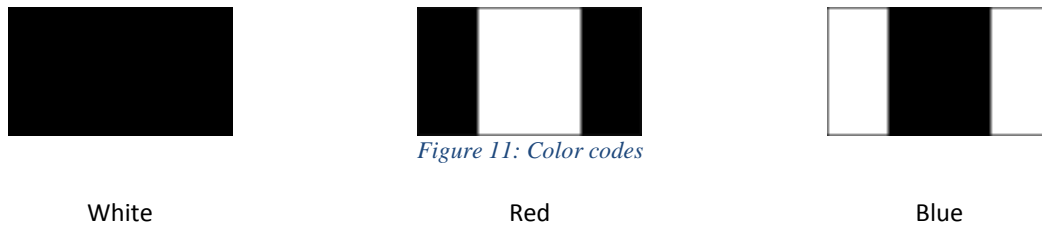

Figure 11 shows the assignment between the codes used and the respective colors. These marks are applied to the workpiece carrier side facing the trail sensor, thus allowing assignment of a workpiece carrier to a colored workpiece. The warehousing with identification is demonstrated in the program "High-bay warehouse barcode" and is not implemented in the factory simulation process.

The static warehousing is used as factory simulation in the program "High-bay warehouse gripper robot". The vacuum gripper robot places the workpiece in the empty workpiece carrier standing ready. This is picked up previously from the robot in the high-bay warehouse and brought to the "conveyor system with identification". Now the workpiece carrier with the workpiece is conveyed by the track sensor and statically stored by the robot in the high-bay warehouse. To move it out of storage the robot picks up the loaded workpiece carrier off of the shelf and transports it to the conveyor system. There the vacuum gripper robot can again pick up the workpiece.

Calibration

The positions traveled by the automated high-bay warehouse feeder are stored in the "Calibration" subroutine. The positions describe the location of the high-bay storage rack slots and the location of the conveyor belt relative to the zero position of the feeder. Only the X and Y positions that are reached using the encoder motors are taken into account. The Z positions that are reached with an S motor are reached with the help of push-button switches and therefore do not need to be calibrated (if necessary the switches must be aligned). The ten positions (new storage locations + conveyor belt) are described with the help of eight variables.

For the storage locations, the levels (three X positions) and rack rows (three Y positions) are stored as variables. In the case of the conveyor belt, the X and Y positions are also stored. The position values can be adapted here as necessary.

Tab. 1: Predefined and modified positions of the high-bay warehouse

Position	Variable name	Predefined value	Adjusted value
Conveyor belt (X position)	X_0	10	
Conveyor belt (Y position)	Y_0	729	
First row	X_1	760	

Second row	X_2	1365	
Third row	X_3	1972	
Top level	Y_1	85	
Middle level	Y_2	460	
Bottom level	Y_3	850	

High-bay warehouse – definition and characteristics

What is a high-bay warehouse?

What is the pre-loading zone?

Identify and label the important areas of the automated high-bay warehouse.

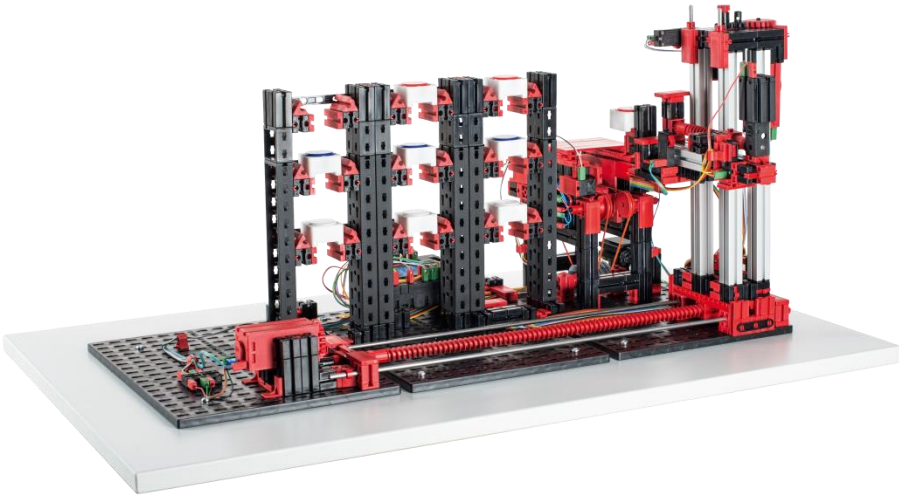

High-bay warehouse – definition and characteristics

ANSWER

What is a high-bay warehouse?

A high-bay warehouse is a space-saving storage area for computer-assisted storage and retrieval of goods and as a result of high standardization provides for a high level of automation.

What is the pre-loading zone?

The pre-loading zone is the high-bay warehouse area where the goods are prepared and identified. The pre-loading zone also includes the high-bay rack feeder and conveyor system.

Identify and label the important areas of the automated high-bay warehouse.

1 High-bay storage rack

2 Conveyor system with identification

3 High-bay rack feeder

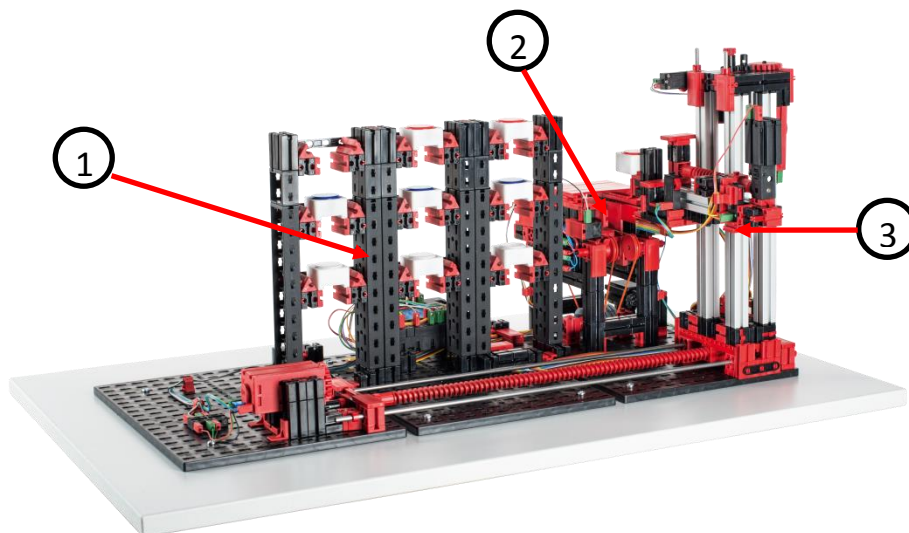

Dynamic warehousing

What are the two requirements for using dynamic warehousing?

What does dynamic warehousing promise?

How can dynamic warehousing be streamlined further?

Use the ABC strategy on the automated high-bay warehouse.

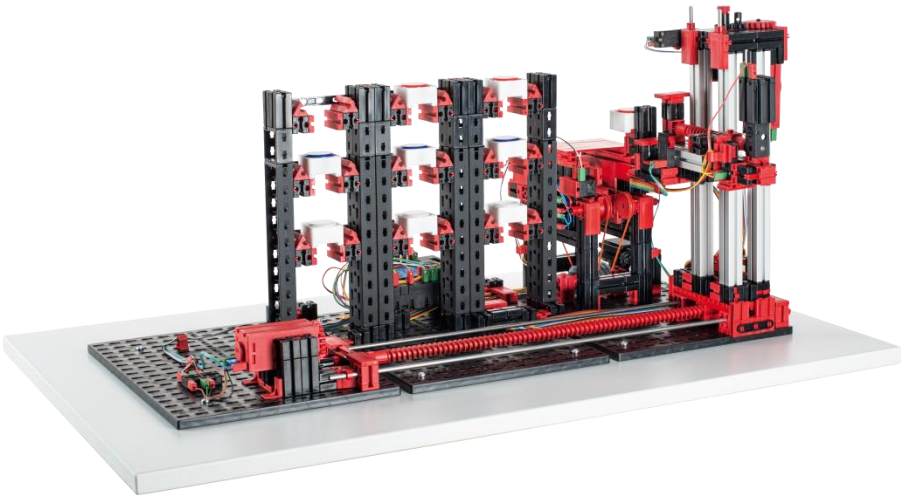

Dynamic warehousing

ANSWER

What are the two requirements for using dynamic warehousing?

- *(Partially) automated identification of goods*
- *Standardization of storage areas*

What does dynamic warehousing promise?

- *Streamlined pathways*
- *Efficient utilization of storage space*

How can dynamic warehousing be streamlined further?

By using the ABC strategy in which frequently required goods are placed close to the storage and retrieval area and rarely needed goods are placed far away from the storage and retrieval area.

Use the ABC strategy on the automated high-bay warehouse.

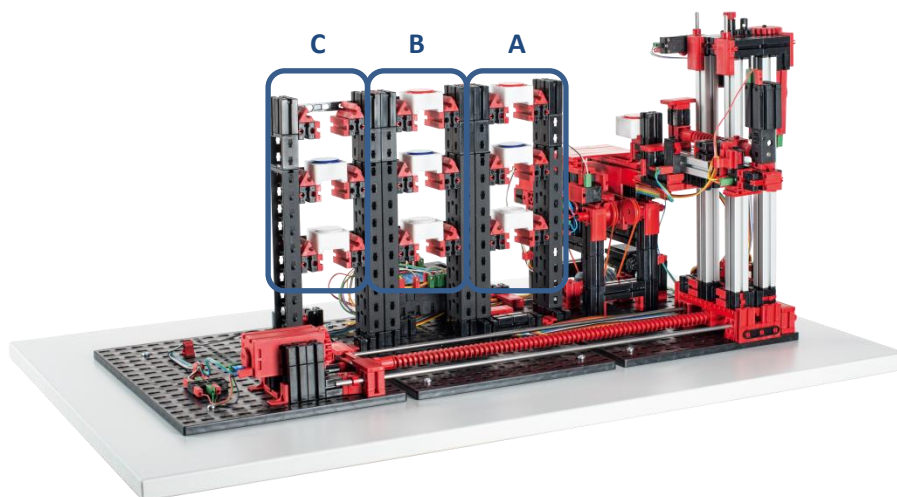

Maintenance and troubleshooting

The automated high-bay warehouse is generally maintenance free. If necessary the grease on the worms and worm screw nuts can be replaced. Keep in mind that it is possible to avoid a friction-type connection by applying a thin layer of grease at specific locations.

Problem: One of the three motors/axes is no longer moving.

Solution: Visually inspect the robot. Specifically check the cabling of the failed motor. If necessary, use a multimeter to check if there is a broken cable.

Problem: One of the three motors/axes moves beyond the specified position and no longer stops on its own.

Solution: Verify that the three encoder cable wires are correctly connected to the TXT controller. The "Interface Test" window may be helpful.

Problem: One of the three motors/axes no longer moves to the positions correctly and pauses briefly in front of the desired position.

Solution: Verify that the robot chucks and chuck nuts are secured tightly. If not, it is possible that there could be slippage between the friction lock parts.

Problem: The conveyor belt does not move or does not move far enough even though there is a workpiece on it.

Solution: One of the two conveyor belt light barriers is not working. Check the light barrier cables and make sure that they are not covered by shifting components. The "Interface Test" window may be helpful.

Problem: The high-bay rack feeder is brushing against the high bay storage rack or is not picking up the workpiece carriers correctly.

Solution: Adjust the positions of the program in the "Calibration" subroutine.

Problem: The high-bay rack feeder does not move from the high bay storage rack.

Solution: The position set on the high bay storage rack is incorrect. When picking up the workpiece carrier, the rack feeder must move upward. If the particular axis moves against a limit stop, the routine remains in an endless loop. To avoid this, adjust the position of this axis so that the workpiece carrier pickup routine does not extend past the limits.

Problem: No program is present on the TXT controller.

Solution: Connect your computer with the TXT controller and load the corresponding program on the TXT controller (Information on this is found in the ROBOPro software under the mask "TXT Controller"). The program is found on the eLearning portal or the example program included with the ROBOPro software under the path: Data carrier – Program (x86) – ROBOPro – Example program – Training models.

Multi processing station with oven

In the case of the multi processing station with oven, the workpiece automatically runs through several stations that simulate different processes. These processes use different conveyor systems, such as a conveyor belt, a turntable and a vacuum gripper robot. Processing begins with the oven. The processing starts as soon as the vacuum gripper robot places the workpiece on the oven feeder. The light barrier is interrupted when this happens, opening the oven door and drawing in the oven feeder. At the same time, the vacuum gripper is called, which brings the workpiece to the turntable after the firing process. Following the firing process, the door of the oven is again opened and the oven feeder moves outward again. The pre-positioned vacuum gripper picks up the workpiece, transports it to the turntable and sets it down there. The turntable positions the workpiece under the saw, waits there while the workpiece is processed and then moves to the position on the conveyor belt. There the pneumatic actuated ejector pushes the workpiece onto the conveyor belt, which conveys the workpiece to a light barrier and then transfers it to the sorting line with detection. Crossing the light barrier causes the turntable to return to its starting position and the conveyor belt to come to a delayed stop.

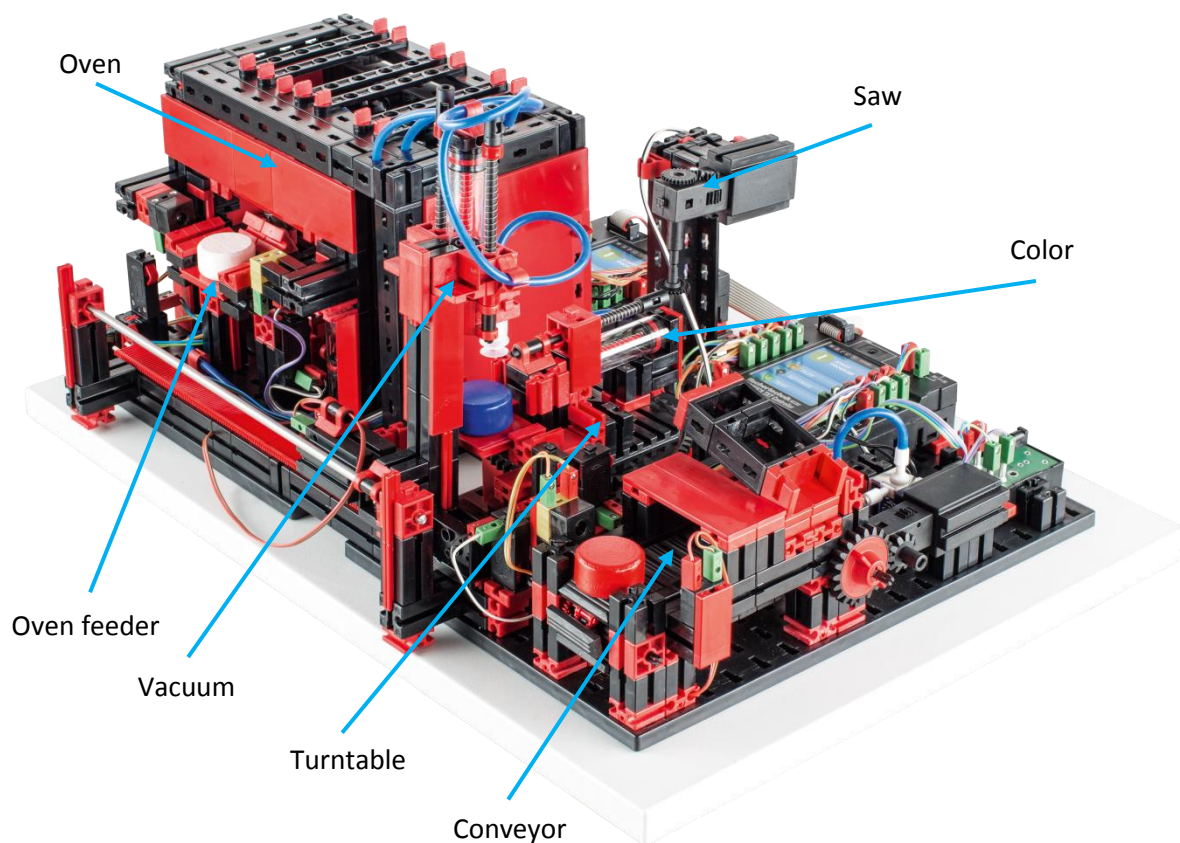

Figure 12: Areas of the multi processing station with oven

The multi processing station with oven is controlled by two TXT controllers, which operate in an integrated master-extension setup. The system is divided into three parts: the oven, vacuum gripper robot and turntable. The particular processes communicate with each other, thereby ensuring among other things that no collisions occur. For instance, the oven triggers movement of the vacuum gripper robot at two locations of the programming sequence, ensuring that the vacuum gripper robot is positioned at the right location when needed while also ensuring that there is something for the gripper to grasp at the location. Likewise, the turntable is activated by the vacuum gripper robot after the workpiece is set down.

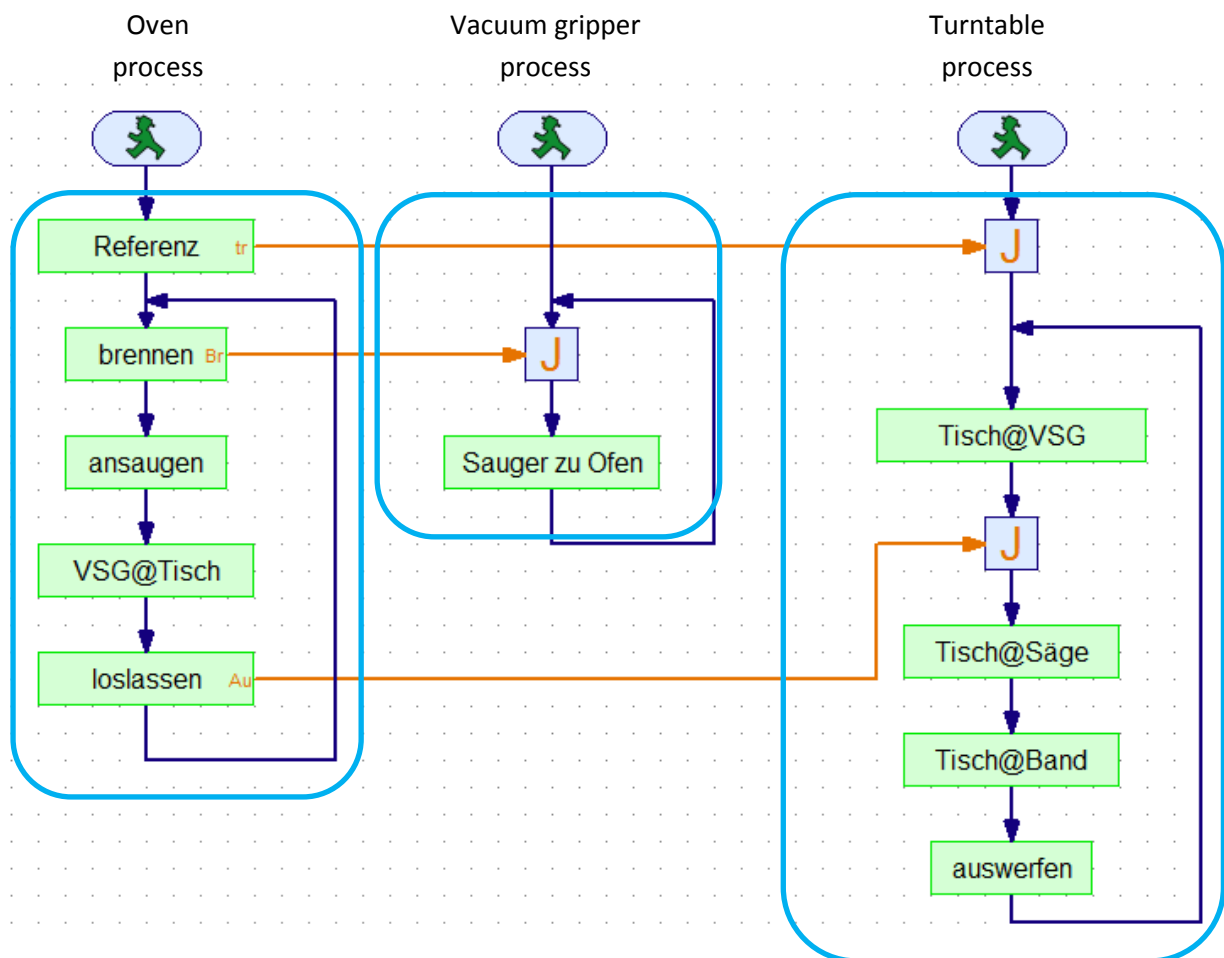
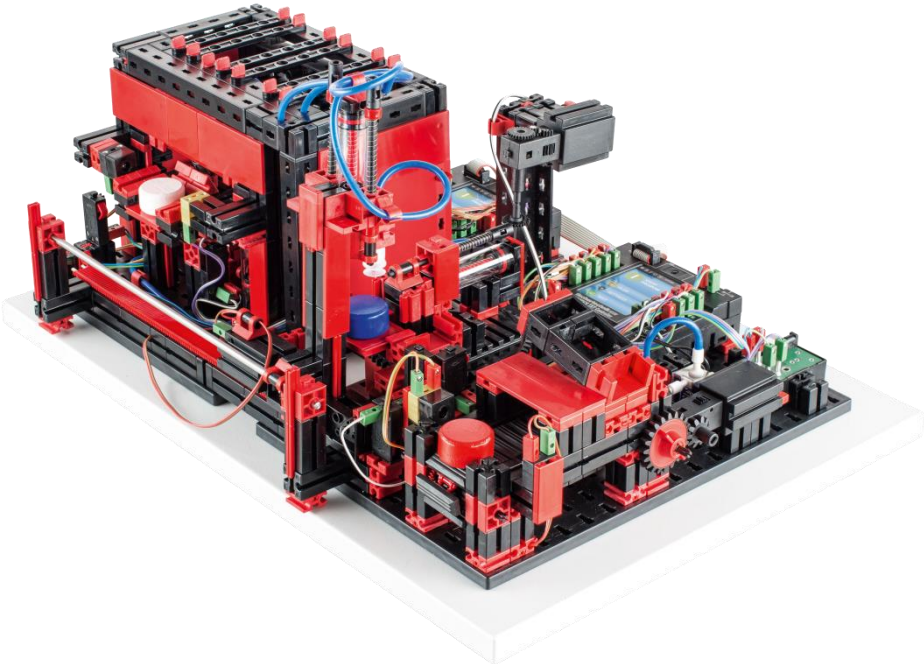

Figure 13: Program areas of the multi processing station with oven

Multi processing station with oven

Identify the “oven”, “vacuum gripper robot”, “turntable” and “conveyor belt” components.



Which three conveyor systems are used with the multi processing station with oven?

Multi processing station with oven

ANSWER

Identify the “oven”, “vacuum gripper robot”, “turntable” and “conveyor belt” components.

1. *Oven*
2. *Vacuum gripper robot*
3. *Turntable*
4. *Conveyor belt*

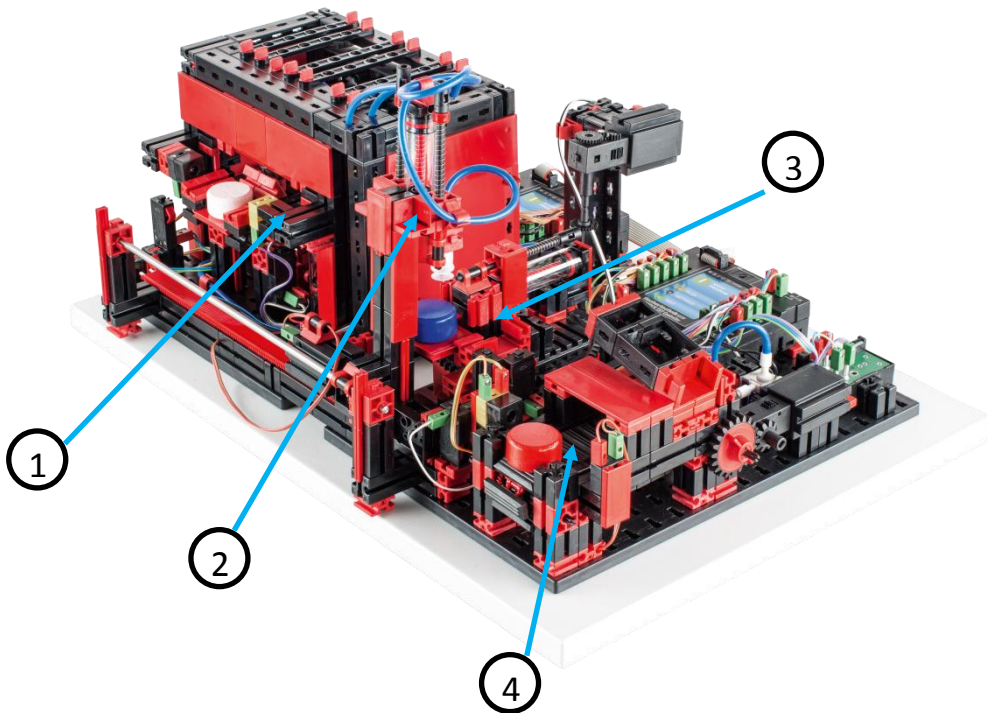

Which three conveyor systems are used with the multi processing station with oven?

- Conveyor belt*
- Turntable*
- Vacuum gripper robot*

Maintenance and troubleshooting

The multi processing station with oven is generally maintenance free.

Problem: The vacuum gripper robot loses workpieces during transport.

Solution: Make sure that the hose connection (Art. No. 35328) end is flush with the top edge of the suction cup. Make sure that the surface of the workpiece is free of contaminants. It may help to moisten the vacuum gripper robot.

Problem: The conveyor belt no longer stops.

Solution: The conveyor belt stops with a delay when the workpiece passes the last light barrier. To stop the conveyor belt you can manually interrupt the light barrier.

Problem: The light barrier on the oven does not detect that a workpiece is on the feeder.

Solution: The light barrier detects that the workpiece has been set down, but does not detect the presence of the workpiece. To start the processing, you can manually interrupt the light barrier. Also make sure that phototransistor will not be triggered by the ambient light.

Problem: The door of the oven does not open/close, or the workpiece is no longer pushed off the turntable.

Solution: Verify that all pneumatic hoses are connected correctly and that the compressor is working properly.

Problem: No program is present on the Master TXT controller.

Solution:

Connect your computer with the Master TXT controller and load the corresponding program on the TXT controller (Information on this is found in the ROBOPRO software under the mask "TXT Controller"). The program is found on the eLearning portal or the example program included with the ROBOPRO software under the path: Data carrier – Program (x86) – ROBOPRO – Example program – Training models.

Sorting line with detection

The sorting line with detection is used for the automated separation of different colored building blocks. In this process, a conveyor belt conveys geometrically identical, yet different colored components to a color sensor, where they are separated according to their color. The conveyor belt is powered by an S motor and the transport route is measured with the help of a pulse switch. The ejection of workpieces is handled by pneumatic cylinders, which are assigned to the appropriate storage locations and are actuated by solenoid valves. Several light barriers control the flow of the workpieces and whether the workpieces are in the storage locations.

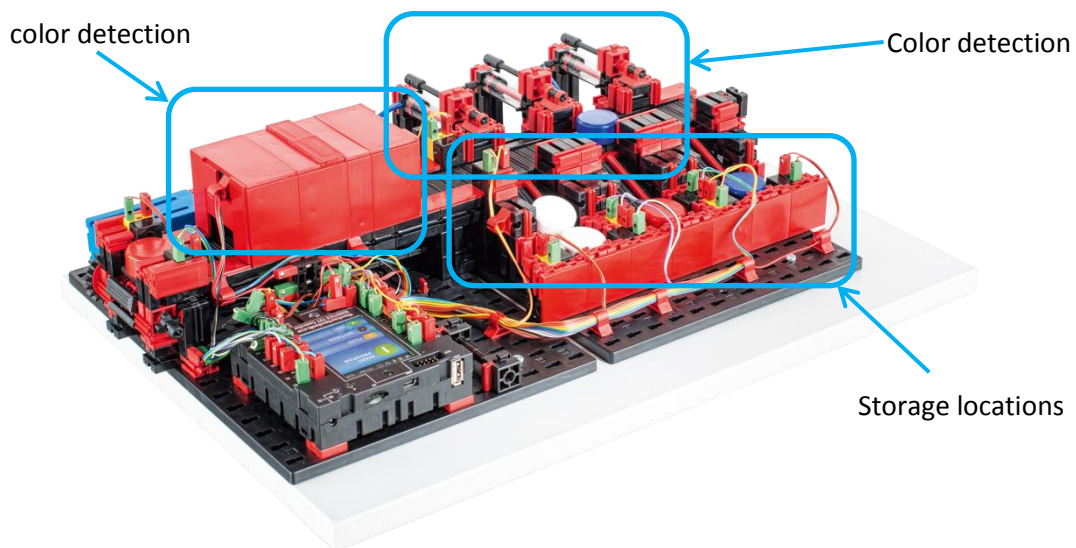

Figure 14: Areas of the sorting line with detection

During this process, color detection is handled by an optical color sensor, which emits a red light and can detect their color based on a surface reflection. Technically speaking the color sensor is therefore a reflective sensor which indicates how well a surface reflects light. The sensor's measured value is therefore not proportional to the wavelength of the measured color and even the assignment of color coordinates or color spaces (e.g. RGB or CMYK) is not possible. In addition to the object's color, ambient light, the surface of the object and the distance of the object from the sensor influence the quality of the reflection. For this reason, it is imperative that the color sensor is protected from ambient light and the surface of the objects are similar. In addition, it is important that the sensor is installed perpendicularly to the object's surface. Threshold values that limit the measured values of individual colors make a distinction between the colored workpieces. Since the value ranges of different color sensors differ, the limit values absolutely must be adjusted.

Ejection is controlled with the help of the light barrier located before the first ejector. Depending on the color value detected, the corresponding pneumatic cylinder is triggered with a delay after the light barrier is halted by the workpiece. This is where the pulse switch comes in, which senses the rotation of the gear wheel driving the conveyor belt.

Unlike a time-dependent delay, this approach can withstand disruptions in the conveyor belt speed. The ejected workpieces are fed through three chutes to the particular storage locations.

The storage locations are equipped with light barriers that detect whether the storage location is filled or not. However, the light barriers cannot tell how many workpieces are in the storage location.

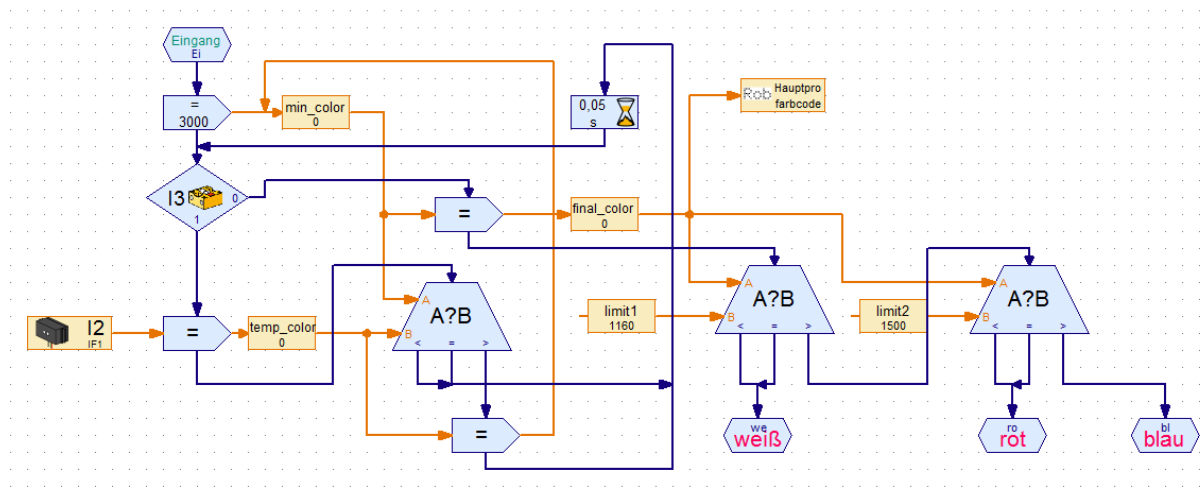

Figure 15: ROBO Pro color detection implementation

After the workpieces are transferred from the processing station to the conveyor belt of the sorting line, the workpiece interrupts a light barrier, which ensures that the process is started and the conveyor is started. For the color detection the workpiece runs through a darkened sluice, in which a color sensor is installed. During this time interval, the minimum value of the measured color value is determined and the workpiece is assigned a color. At the time when the workpiece is needed, in order to pass by the color sensor, the minimum value is compared to the current measured value and is replaced by this value if necessary. A value is selected as the initial value of the minimum value; this value is higher than the maximum value of the color sensor. This ensures that the minimum value is actually equal to the lowest measured value and not the initial value. The determined minimum value is then compared to the two limit values in order to obtain the assignment to the colors white, red and blue. In some cases the limit values have to be adjusted to other operating conditions. If the workpiece is assigned a color, this is pushed by the corresponding pneumatic cylinder from the conveyor belt in the corresponding storage location. During this the storage location, which is found closest to the detection is assigned the color white, the center the color red and the furthest away the color blue. From this storage location the vacuum gripper robot can now again pick up the workpiece and transport it to the high-bay warehouse to store it there again.

Calibration

Due to different environmental influences and variations in the color sensor, the sorting line with detection needs to be calibrated. To do this, the limit values used to distinguish the different colors need to be set in the "Calibration" subroutine. While the first limit value "limit1" is used to distinguish between white and red, the second limit value "limit2" is used to distinguish between red and blue. To adapt the limit values, first take a few measured values. During this place the workpiece under the color sensor and read the current value of the reflection either directly from the TXT controller, or via the "Interface Test". Pay attention that after a change the program must be loaded again onto the TXT controller, in order to start it via the controller.

Tab. 2: Predefined and modified limit values of the color sensor

Limit value	Predefined value	Adjusted value
limit1	1320	
limit2	1550	

color detection

Briefly describe how the color sensor, which is used in the sorting line, works.

Which interference factors can affect the measured value of the color sensor?

What are the physical requirements to ensure fault-free operation of the color sensor?

Name two common color spaces.

What might a color sensor look like that consists of reflective sensors and outputs an actual color value?

color detection

ANSWER

Briefly describe how the color sensor, which is used in the sorting line, works.

The color sensor used is a reflective sensor. It measures the reflection of red light, which is reflected by the object to be measured.

Which interference factors can affect the measured value of the color sensor?

Ambient light

Surface of the detected object

Reflection angle

What are the physical requirements to ensure fault-free operation of the color sensor?

The color sensor must be protected from ambient light (e.g. housing)

The surface of the objects to be measured must be similar.

Name two common color spaces and name their basic colors.

RGB (red - green - blue)

CMYK (cyan - magenta - yellow - key (black))

What might a color sensor look like that consists of reflective sensors and outputs an actual color value?

A color sensor that outputs an actual color value must consist of three reflective sensors. In the RGB color space, these sensors must emit red, green and blue light sequentially and then measure each reflection.

Sorting line with detection

Identify the “color detection”, “ejector” and “storage location” areas.

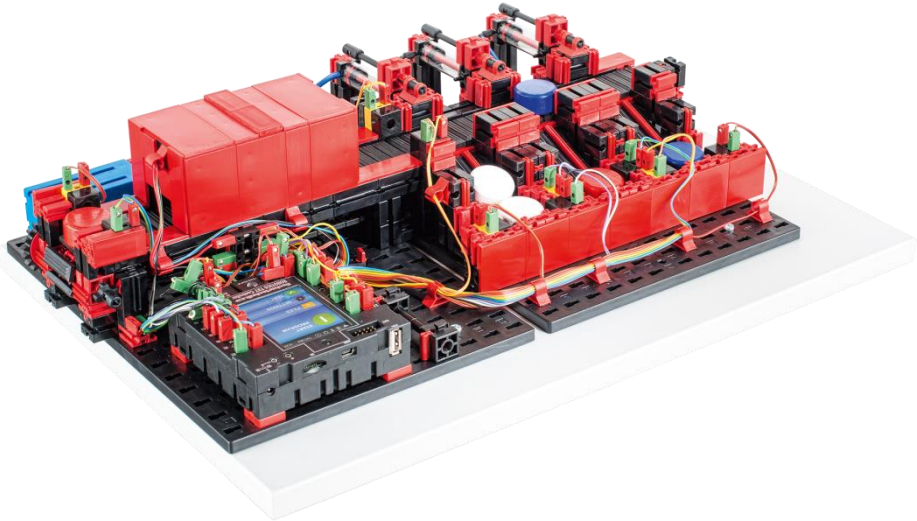

Sorting line with detection

ANSWER

Identify the “color detection”, “ejector” and “storage location” areas.

1. *color detection*
2. *Color detection*
3. *Storage locations*

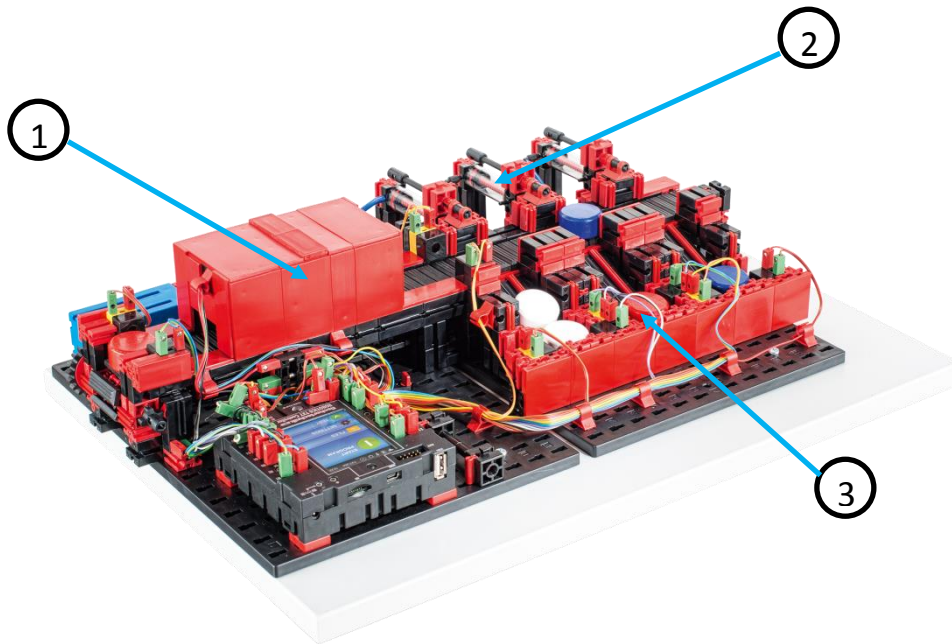

Maintenance and troubleshooting

The sorting line is generally maintenance free.

Problem: **The sorting line is not sorting the colored workpieces correctly.**

Solution: Adjust the limit values in the "Configuration" subroutine. Also make sure that ambient light is not interfering with the color sensor.

Problem: **The workpieces are not being pushed off, but the conveyor is still in the correct location.**

Solution: Make sure that the pneumatic hoses are connected correctly and that the compressor is running correctly.

Problem: **The conveyor belt is not starting or is stopping too soon.**

Solution: Verify that the light barriers in front of the color detector and in front of the ejector are working correctly and that they are connected properly. When doing so, make sure the polarity of the phototransistor is correct.

Problem: **No program is present on the TXT controller.**

Solution: Connect your computer with the TXT controller and load the corresponding program on the TXT controller (Information on this is found in the ROBOPRO software under the mask "TXT Controller"). The program is found on the eLearning portal or the example program included with the ROBOPRO software under the path: Data carrier – Program (x86) – ROBOPRO – Example program – Training models.