



ENCODER MOTOR 9V

Art. Nr. 186175

MOTOR

Voltage Suggested	9.0 DC Constant between motor terminals
Operating Temperature Range	Between 0°C to +50°C
Storage Humidity Range	Between 20% to 70%
Reduction Ratio	1:21.3
No Load Speed	280(±35) rpm
No Load Current	0.18A max.
Stall Torque	2.5 kgcm min.
Stall Current	3.0 A max.

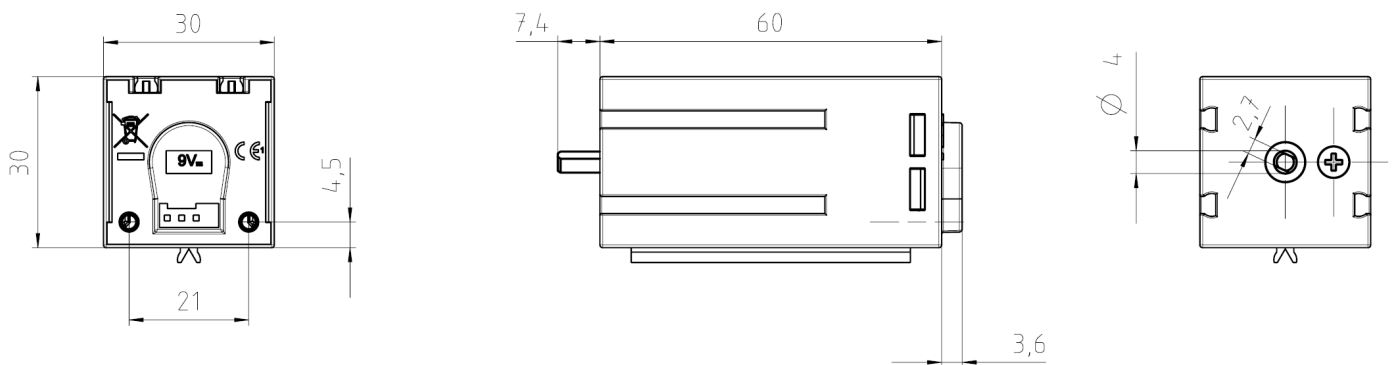

ENCODER

Signal	Push-Pull Output (0/9V), max. 10 mA
Frequency	max. 1 kHz
Connector	3-pin header
Fitting Cable	Art. Nr. 137125, Art. Nr. 168961
Supply Voltage Encoder	3,3 - 9V DC
Signal	npn open collector output, max. 2 mA

When the encoder motor is connected to a digital input of any control units (not fischertechnik controllers) a pull-up resistance of 4.7-10 kOhms is needed between the encoder signal and the encoder power supply (3.3V or 5V).

Resolution of encoder: 3 pulses (6 pulses when counting 0-1 and 1-0 edge) per round of motor. 63.9/127.8 pulses per round of the gear shaft.

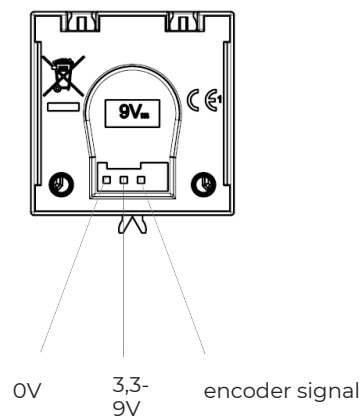

NO LOAD		AT MAX. EFFICIENCY					STALL	
SPEED (r.p.m)	CURRENT (A)	SPEED (r.p.m.)	CURRENT (A)	TORQUE (g.cm)	OUT PUT (W)	EFFICIENCY (%)	CURRENT (A)	TORQUE (g.cm)
280	0.12	230	0.51	624	1.44	31.5	2.1	3200

REFERENCE ONLY

